

SECTION **FSU**  
FRONT SUSPENSION

A  
B  
C  
D

FSU

CONTENTS

<p><b>2WD</b></p> <p><b>SYMPTOM DIAGNOSIS</b> ..... 3</p> <p><b>NOISE, VIBRATION AND HARSHNESS (NVH) TROUBLESHOOTING</b> ..... 3</p> <p>    NVH Troubleshooting Chart .....3</p> <p><b>PRECAUTION</b> ..... 4</p> <p><b>PRECAUTIONS</b> ..... 4</p> <p>    Precaution for Supplemental Restraint System (SRS) "AIR BAG" and "SEAT BELT PRE-TENSIONER" .....4</p> <p>    Precaution Necessary for Steering Wheel Rotation after Battery Disconnect .....4</p> <p>    Precaution for Procedure without Cowl Top Cover.....5</p> <p>    Precautions for Suspension .....5</p> <p><b>PREPARATION</b> ..... 6</p> <p><b>PREPARATION</b> ..... 6</p> <p>    Special Service Tool .....6</p> <p>    Commercial Service Tool .....6</p> <p><b>PERIODIC MAINTENANCE</b> ..... 7</p> <p><b>FRONT SUSPENSION ASSEMBLY</b> ..... 7</p> <p>    Inspection .....7</p> <p><b>WHEEL ALIGNMENT</b> ..... 8</p> <p>    Inspection .....8</p> <p><b>REMOVAL AND INSTALLATION</b> ..... 9</p> <p><b>FRONT COIL SPRING AND SHOCK ABSORBER</b> ..... 9</p> <p>    Exploded View .....9</p> <p>    Removal and Installation .....10</p> <p>    Disassembly and Assembly .....10</p> <p>    Inspection .....12</p> <p>    Disposal .....13</p>	<p><b>TRANSVERSE LINK</b> .....14</p> <p>    Exploded View .....14</p> <p>    Removal and Installation .....15</p> <p>    Inspection .....15</p> <p><b>UPPER LINK</b> .....17</p> <p>    Exploded View .....17</p> <p>    Removal and Installation .....18</p> <p>    Inspection .....18</p> <p><b>FRONT STABILIZER</b> .....19</p> <p>    Exploded View .....19</p> <p>    Removal and Installation .....20</p> <p>    Inspection .....20</p> <p><b>UNIT REMOVAL AND INSTALLATION</b> .....21</p> <p><b>FRONT SUSPENSION MEMBER</b> .....21</p> <p>    Exploded View .....21</p> <p>    Removal and Installation .....22</p> <p>    Inspection .....22</p> <p><b>SERVICE DATA AND SPECIFICATIONS (SDS)</b> .....23</p> <p><b>SERVICE DATA AND SPECIFICATIONS (SDS)</b> .....23</p> <p>    Wheel Alignment .....23</p> <p>    Ball Joint .....23</p> <p>    Wheelarch Height .....23</p> <p style="text-align: center;"><b>AWD</b></p> <p><b>SYMPTOM DIAGNOSIS</b> .....25</p> <p><b>NOISE, VIBRATION AND HARSHNESS (NVH) TROUBLESHOOTING</b> .....25</p> <p>    NVH Troubleshooting Chart .....25</p> <p><b>PRECAUTION</b> .....26</p> <p><b>PRECAUTIONS</b> .....26</p>	<p>F G H I J K L M N O P</p>
--	---	--

Precaution for Supplemental Restraint System (SRS) "AIR BAG" and "SEAT BELT PRE-TENSIONER" .....	26	<b>TRANSVERSE LINK</b> .....	<b>36</b>
Precaution Necessary for Steering Wheel Rotation after Battery Disconnect .....	26	Exploded View .....	36
Precaution for Procedure without Cowl Top Cover..	27	Removal and Installation .....	37
Precautions for Suspension .....	27	Inspection .....	37
<b>PREPARATION</b> .....	<b>28</b>	<b>UPPER LINK</b> .....	<b>39</b>
<b>PREPARATION</b> .....	<b>28</b>	Exploded View .....	39
Special Service Tool .....	28	Removal and Installation .....	40
Commercial Service Tool .....	28	Inspection .....	40
<b>PERIODIC MAINTENANCE</b> .....	<b>29</b>	<b>FRONT STABILIZER</b> .....	<b>41</b>
<b>FRONT SUSPENSION ASSEMBLY</b> .....	<b>29</b>	Exploded View .....	41
Inspection .....	29	Removal and Installation .....	42
<b>WHEEL ALIGNMENT</b> .....	<b>30</b>	Inspection .....	42
Inspection .....	30	<b>UNIT REMOVAL AND INSTALLATION</b> ....	<b>43</b>
<b>REMOVAL AND INSTALLATION</b> .....	<b>31</b>	<b>FRONT SUSPENSION MEMBER</b> .....	<b>43</b>
<b>FRONT COIL SPRING AND SHOCK ABSORBER</b> .....	<b>31</b>	Exploded View .....	43
Exploded View .....	31	Removal and Installation .....	44
Removal and Installation .....	32	Inspection .....	44
Disassembly and Assembly .....	32	<b>SERVICE DATA AND SPECIFICATIONS (SDS)</b> .....	<b>45</b>
Inspection .....	35	<b>SERVICE DATA AND SPECIFICATIONS (SDS)</b> .....	<b>45</b>
Disposal .....	35	Wheel Alignment .....	45
		Ball Joint .....	45
		Wheelarch Height .....	45

# NOISE, VIBRATION AND HARSHNESS (NVH) TROUBLESHOOTING

< SYMPTOM DIAGNOSIS >

[2WD]

## SYMPTOM DIAGNOSIS

### NOISE, VIBRATION AND HARSHNESS (NVH) TROUBLESHOOTING

#### NVH Troubleshooting Chart

INFOID:000000005655649

Use chart below to find the cause of the symptom. If necessary, repair or replace these parts.

Symptom		Possible cause and SUSPECTED PARTS													Reference page			
		Improper installation, looseness	Shock absorber deformation, damage or deflection	Bushing or mounting deterioration	Parts interference	Spring fatigue	Suspension looseness	Incorrect wheel alignment	Stabilizer bar fatigue	PROPELLER SHAFT	FRONT AXLE AND FRONT SUSPENSION	ROAD WHEEL	BRAKE	STEERING				
Symptom	FRONT SUSPENSION	Noise	x	x	x	x	x	x			x	x	x	x	x		FSU-9, FSU-14, FSU-17, FSU-19, FSU-21	
		Shake	x	x	x	x		x			x	x	x	x	x		FSU-12	
		Vibration	x	x	x	x	x				x	x						—
		Shimmy	x	x	x	x				x								—
		Judder	x	x	x							x	x	x	x			FSU-9, FSU-14, FSU-17, FSU-19, FSU-21
		Poor quality ride or handling	x	x	x	x	x			x	x		x	x				FSU-8 FSU-20
																	NVH in DLN section	
																	NVH in FAX and FSU section	
																	NVH in WT section	
																	NVH in BR section	
																	NVH in ST section	

x: Applicable

A  
B  
C  
D  
E  
F  
G  
H  
I  
J  
K  
L  
M  
N  
O  
P

FSU

## PRECAUTION

### PRECAUTIONS

#### Precaution for Supplemental Restraint System (SRS) "AIR BAG" and "SEAT BELT PRE-TENSIONER"

INFOID:000000005853497

The Supplemental Restraint System such as "AIR BAG" and "SEAT BELT PRE-TENSIONER", used along with a front seat belt, helps to reduce the risk or severity of injury to the driver and front passenger for certain types of collision. This system includes seat belt switch inputs and dual stage front air bag modules. The SRS system uses the seat belt switches to determine the front air bag deployment, and may only deploy one front air bag, depending on the severity of a collision and whether the front occupants are belted or unbelted. Information necessary to service the system safely is included in the "SRS AIR BAG" and "SEAT BELT" of this Service Manual.

**WARNING:**

- To avoid rendering the SRS inoperative, which could increase the risk of personal injury or death in the event of a collision which would result in air bag inflation, all maintenance must be performed by an authorized NISSAN/INFINITI dealer.
- Improper maintenance, including incorrect removal and installation of the SRS, can lead to personal injury caused by unintentional activation of the system. For removal of Spiral Cable and Air Bag Module, see the "SRS AIR BAG".
- Do not use electrical test equipment on any circuit related to the SRS unless instructed to in this Service Manual. SRS wiring harnesses can be identified by yellow and/or orange harnesses or harness connectors.

#### PRECAUTIONS WHEN USING POWER TOOLS (AIR OR ELECTRIC) AND HAMMERS

**WARNING:**

- When working near the Air Bag Diagnosis Sensor Unit or other Air Bag System sensors with the ignition ON or engine running, DO NOT use air or electric power tools or strike near the sensor(s) with a hammer. Heavy vibration could activate the sensor(s) and deploy the air bag(s), possibly causing serious injury.
- When using air or electric power tools or hammers, always switch the ignition OFF, disconnect the battery, and wait at least 3 minutes before performing any service.

#### Precaution Necessary for Steering Wheel Rotation after Battery Disconnect

INFOID:000000005853503

**NOTE:**

- Before removing and installing any control units, first turn the push-button ignition switch to the LOCK position, then disconnect both battery cables.
- After finishing work, confirm that all control unit connectors are connected properly, then re-connect both battery cables.
- Always use CONSULT-III to perform self-diagnosis as a part of each function inspection after finishing work. If a DTC is detected, perform trouble diagnosis according to self-diagnosis results.

For vehicle with steering lock unit, if the battery is disconnected or discharged, the steering wheel will lock and cannot be turned.

If turning the steering wheel is required with the battery disconnected or discharged, follow the operation procedure below before starting the repair operation.

#### OPERATION PROCEDURE

1. Connect both battery cables.

**NOTE:**

Supply power using jumper cables if battery is discharged.

2. Turn the push-button ignition switch to ACC position.  
(At this time, the steering lock will be released.)
3. Disconnect both battery cables. The steering lock will remain released with both battery cables disconnected and the steering wheel can be turned.
4. Perform the necessary repair operation.

# PRECAUTIONS

[2WD]

## < PRECAUTION >

5. When the repair work is completed, re-connect both battery cables. With the brake pedal released, turn the push-button ignition switch from ACC position to ON position, then to LOCK position. (The steering wheel will lock when the push-button ignition switch is turned to LOCK position.)
6. Perform self-diagnosis check of all control units using CONSULT-III.

### Precaution for Procedure without Cowl Top Cover

INFOID:000000005853648

When performing the procedure after removing cowl top cover, cover the lower end of windshield with urethane, etc.

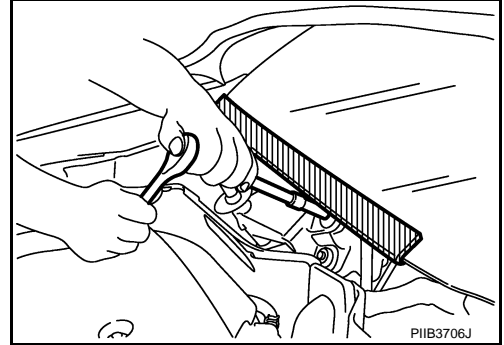

### Precautions for Suspension

INFOID:000000005655653

- When installing rubber bushings, the final tightening must be carried out under unladen conditions with tires on ground. Spilled oil might shorten the life of rubber bushings. Be sure to wipe off any spilled oil.
- Unladen conditions mean that fuel, engine coolant and lubricant are full. Spare tire, jack, hand tools and mats are in designated positions.
- After servicing suspension parts, be sure to check wheel alignment.
- Self-lock nuts are not reusable. Always use new ones when installing. Since new self-lock nuts are pre-oiled, tighten as they are.

# PREPARATION

< PREPARATION >

[2WD]

## PREPARATION

### PREPARATION

#### Special Service Tool

INFOID:000000005655654

The actual shapes of Kent-Moore tools may differ from those of special service tools illustrated here.

Tool number (Kent-Moore No.) Tool name	Description
ST35652000 ( - ) Shock absorber attachment	Disassembling and assembling shock absorber
ST3127S000 (J-25765-A) Preload gauge	Measuring rotating torque of ball joint

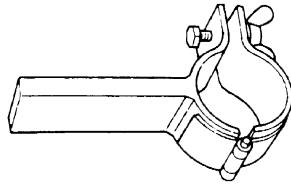

ZZA0807D

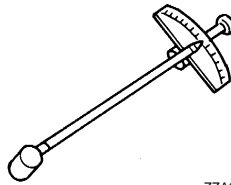

ZZA0806D

#### Commercial Service Tool

INFOID:000000005655655

Tool name	Description
Power tool	Loosening bolts and nuts
Spring compressor	Removing and installing coil spring

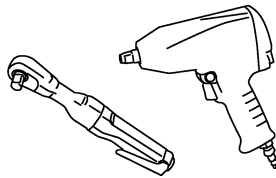

PBIC0190E

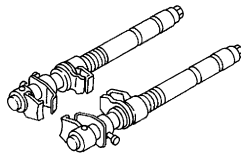

S-NT717

# FRONT SUSPENSION ASSEMBLY

< PERIODIC MAINTENANCE >

[2WD]

## PERIODIC MAINTENANCE

### FRONT SUSPENSION ASSEMBLY

#### Inspection

INFOID:000000005655656

#### MOUNTING INSPECTION

Make sure the mounting conditions (looseness, backlash) of each component and component conditions (wear, damage) are normal.

#### BALL JOINT AXIAL END PLAY

1. Set front wheels in a straight-ahead position.

**CAUTION:**

**Never depress brake pedal.**

2. Place an iron bar or equivalent between transverse link or upper link and steering knuckle.
3. Measure axial end play by prying it up and down.

**Standard**

**Axial end play** : Refer to [FSU-23, "Ball Joint"](#).

**CAUTION:**

**Be careful not to damage ball joint boot. never damage the installation position by applying excessive force.**

#### SHOCK ABSORBER

Check for oil leakage, damage and replace if malfunction is detected.

A  
B  
C  
D  
E  
F  
G  
H  
I  
J  
K  
L  
M  
N  
O  
P

FSU

## WHEEL ALIGNMENT

### Inspection

INFOID:000000005655657

### DESCRIPTION

#### CAUTION:

- **Camber, caster, kingpin inclination angles cannot be adjusted.**
- **If camber, caster, or kingpin inclination angle is outside the standard, check front suspension parts for wear and damage. Replace suspect parts if a malfunction is detected.**
- **Kingpin inclination angle is reference value, no inspection is required.**
- **Measure wheel alignment under unladen conditions.**

#### NOTE:

“Unladen conditions” means that fuel, engine coolant, and lubricant are full. Spare tire, jack, hand tools and mats are in designated positions.

### GENERAL INFORMATION AND RECOMMENDATIONS

- A four-wheel thrust alignment should be performed.
- This type of alignment is recommended for any NISSAN/INFINITI vehicle.
- The four-wheel “thrust” process helps ensure that the vehicle is properly aligned and the steering wheel is centered.
- The alignment rack itself should be capable of accepting any NISSAN/INFINITI vehicle.
- The rack should be checked to ensure that it is level.
- Make sure the machine is properly calibrated.
- Your alignment equipment should be regularly calibrated in order to give correct information.
- Check with the manufacturer of your specific equipment for their recommended Service/Calibration Schedule.

### ALIGNMENT PROCESS

#### IMPORTANT:

Use only the alignment specifications listed in this Service Manual.

- When displaying the alignment settings, many alignment machines use “indicators”: (Green/red, plus or minus, Go/No Go). **Never use these indicators.**
- The alignment specifications programmed into your machine that operate these indicators may not be correct.
- This may result in an ERROR.
- Some newer alignment machines are equipped with an “optional Rolling Compensation” method to “compensate” the sensors (alignment targets or head units). **Never use this “Rolling Compensation” method.**
- Use the “Jacking Compensation Method”. After installing the alignment targets or head units, raise the vehicle and rotate the wheels 1/2 turn both ways.
- See Instructions in the alignment machine you're using for more information on this.

### PRELIMINARY CHECK

Check the following:

- Tires for improper air pressure and wear.
- Road wheels for runout. Refer to [WT-56, "Inspection"](#).
- Wheel bearing axial end play. Refer to [FAX-6, "Inspection"](#).
- Transverse link or upper link ball joint axial end play. Refer to [FSU-23, "Ball Joint"](#), [FSU-18, "Inspection"](#).
- Shock absorber operation.
- Each mounting part of axle and suspension for looseness and deformation.
- Each of suspension member, shock absorber, upper link and transverse link for cracks, deformation and other damage.
- Vehicle height (posture).



# FRONT COIL SPRING AND SHOCK ABSORBER

< REMOVAL AND INSTALLATION >

[2WD]

## REMOVAL AND INSTALLATION

### FRONT COIL SPRING AND SHOCK ABSORBER

Exploded View

INFOID:000000005655658

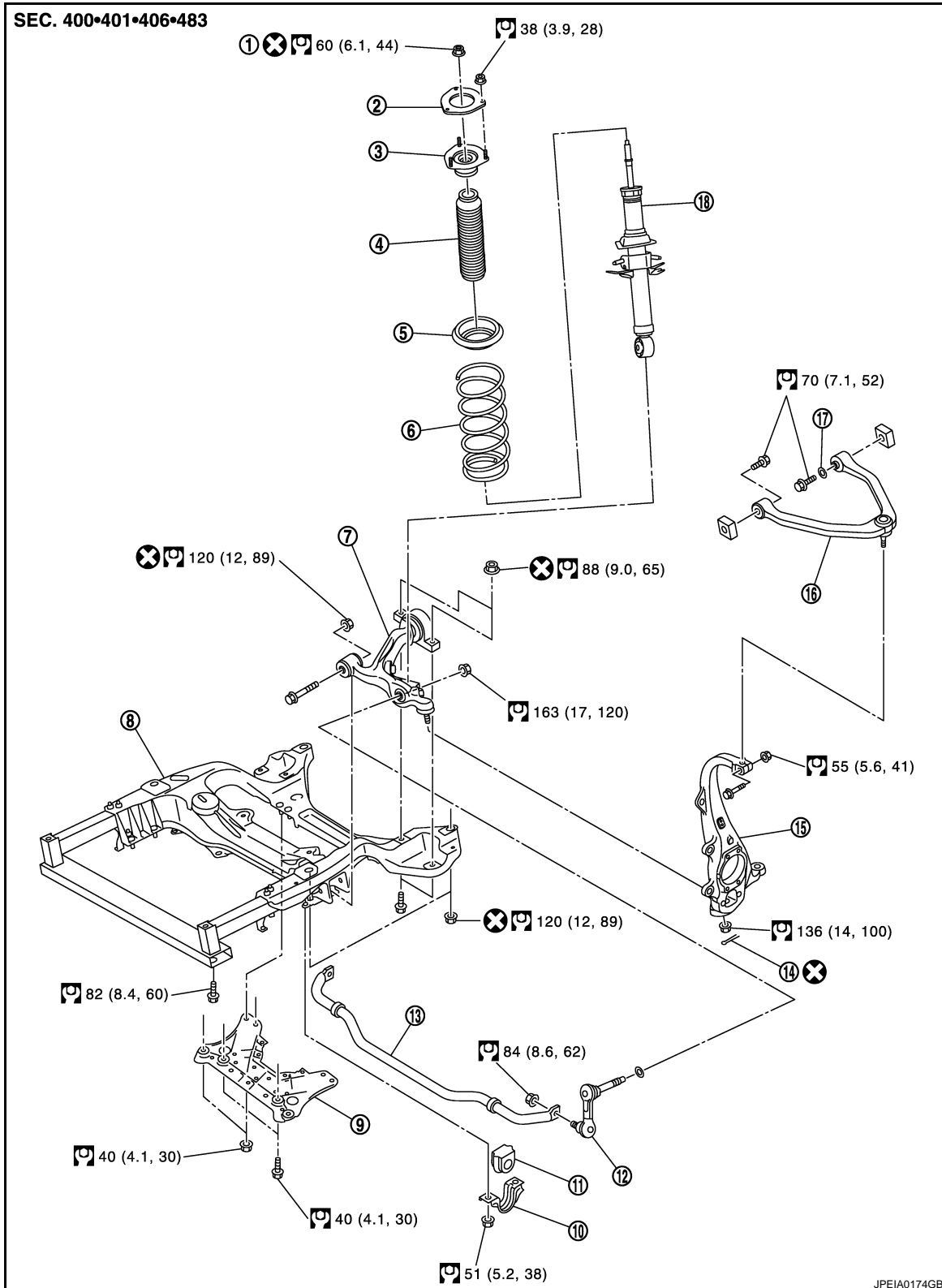

A  
B  
C  
D  
E  
F  
G  
H  
I  
J  
K  
L  
M  
N  
O  
P

FSU

# FRONT COIL SPRING AND SHOCK ABSORBER

< REMOVAL AND INSTALLATION >

[2WD]

- |                        |                            |                                    |
|------------------------|----------------------------|------------------------------------|
| 1. Piston rod lock nut | 2. Mounting seal           | 3. Shock absorber mounting bracket |
| 4. Bound bumper        | 5. Rubber seat             | 6. Coil spring                     |
| 7. Transverse link     | 8. Front suspension member | 9. Suspension member stay          |
| 10. Stabilizer clamp   | 11. Stabilizer bushing     | 12. Stabilizer connecting rod      |
| 13. Stabilizer bar     | 14. Cotter pin             | 15. Steering knuckle               |
| 16. Upper link         | 17. Stopper rubber         | 18. Shock absorber                 |

Refer to [GI-4, "Components"](#) for symbols in the figure.

## Removal and Installation

INFOID:000000005655659

### REMOVAL

1. Remove tires with power tool.
2. Remove harness of the wheel sensor from shock absorber. Refer to [BRC-103, "Exploded View"](#).  
**CAUTION:**  
**Never pull on wheel sensor harness.**
3. Remove brake hose bracket. Refer to [BR-21, "FRONT : Exploded View"](#).
4. Remove stabilizer connecting rod mounting nuts (lower side) with power tool.
5. Remove stabilizer connecting rod mounting nuts (upper side) with power tool, and then remove stabilizer connecting rod from transverse link.
6. Separate upper link from steering knuckle.
7. Remove mounting nuts of shock absorber mounting bracket, then remove shock absorber assembly.

### INSTALLATION

Note the following, and install in the reverse order of removal.

- Never tap on the ball joint cap of the stabilizer connecting rod with a hammer or a similar item when inserting the stabilizer connecting rod into the transverse link.
- Perform final tightening of bolts and nuts at the shock absorber lower side (rubber bushing), under unladen conditions with tires on level ground.

## Disassembly and Assembly

INFOID:000000005655660

### DISASSEMBLY

#### **CAUTION:**

**Never damage shock absorber piston rod when removing components from shock absorber.**

1. Install shock absorber attachment (A) [SST: ST35652000 ( - )] to shock absorber and secure it in a vise.

#### **CAUTION:**

**When installing the shock absorber attachment to shock absorber, wrap a shop cloth around shock absorber to protect it from damage.**

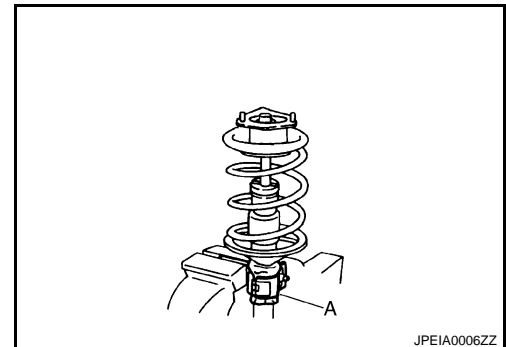

JPEIA0006ZZ

# FRONT COIL SPRING AND SHOCK ABSORBER

## < REMOVAL AND INSTALLATION >

[2WD]

- Using a spring compressor (A) (commercial service tool), compress coil spring between rubber seat and shock absorber until coil spring with a spring compressor is free.

**CAUTION:**

**Be sure a spring compressor is securely attached coil spring. Compress coil spring.**

- Make sure coil spring with a spring compressor between rubber seat and shock absorber is free and then remove piston rod lock nut while securing the piston rod tip so that piston rod does not turn.
- Remove mounting seal, shock absorber mounting bracket, rubber seat, bound bumper from shock absorber.
- Remove coil spring with a spring compressor, and then gradually release a spring compressor.

**CAUTION:**

**Loosen while making sure coil spring attachment position does not move.**

- Remove the shock absorber attachment from shock absorber.

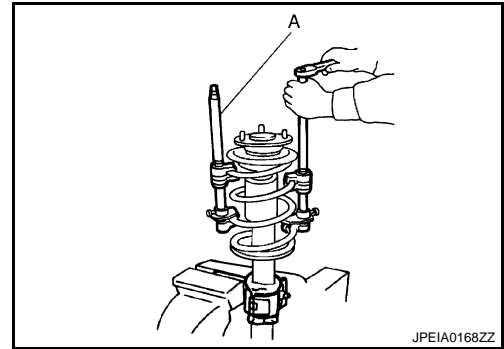

## ASSEMBLY

- Install shock absorber attachment (A) [SST: ST35652000 ( - )] to shock absorber and secure it in a vise.

**CAUTION:**

**When installing the shock absorber attachment to shock absorber, wrap a shop cloth around shock absorber to protect it from damage.**

- Compress coil spring using a spring compressor (commercial service tool), and install it onto shock absorber.

**CAUTION:**

- Install with the large-diameter side (A) facing up and the small-diameter side (B) facing down.
- Be sure a spring compressor is securely attached to coil spring. Compress coil spring.

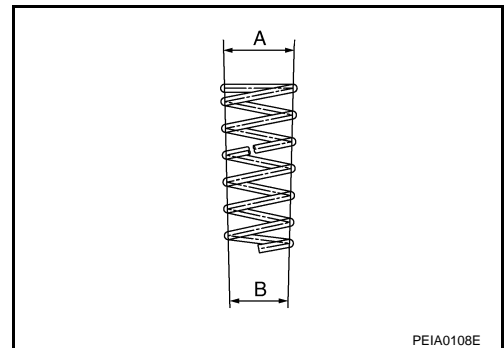

- Install the shock absorber mounting bracket and rubber seat.

**CAUTION:**

**Align the paint mark (A) to the stud bolt (1) position when assembling.**

- Apply soapy water to bound bumper.

**CAUTION:**

**Never use machine oil.**

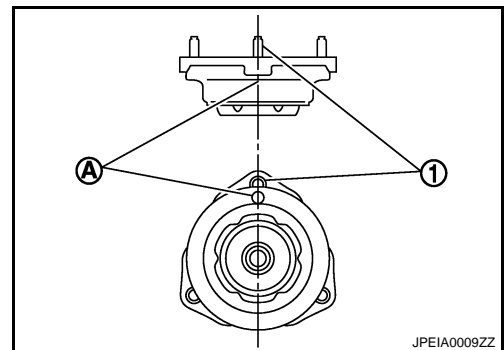

# FRONT COIL SPRING AND SHOCK ABSORBER

< REMOVAL AND INSTALLATION >

[2WD]

5. Insert bound bumper into shock absorber mounting bracket, and then install it to shock absorber together with rubber seat.

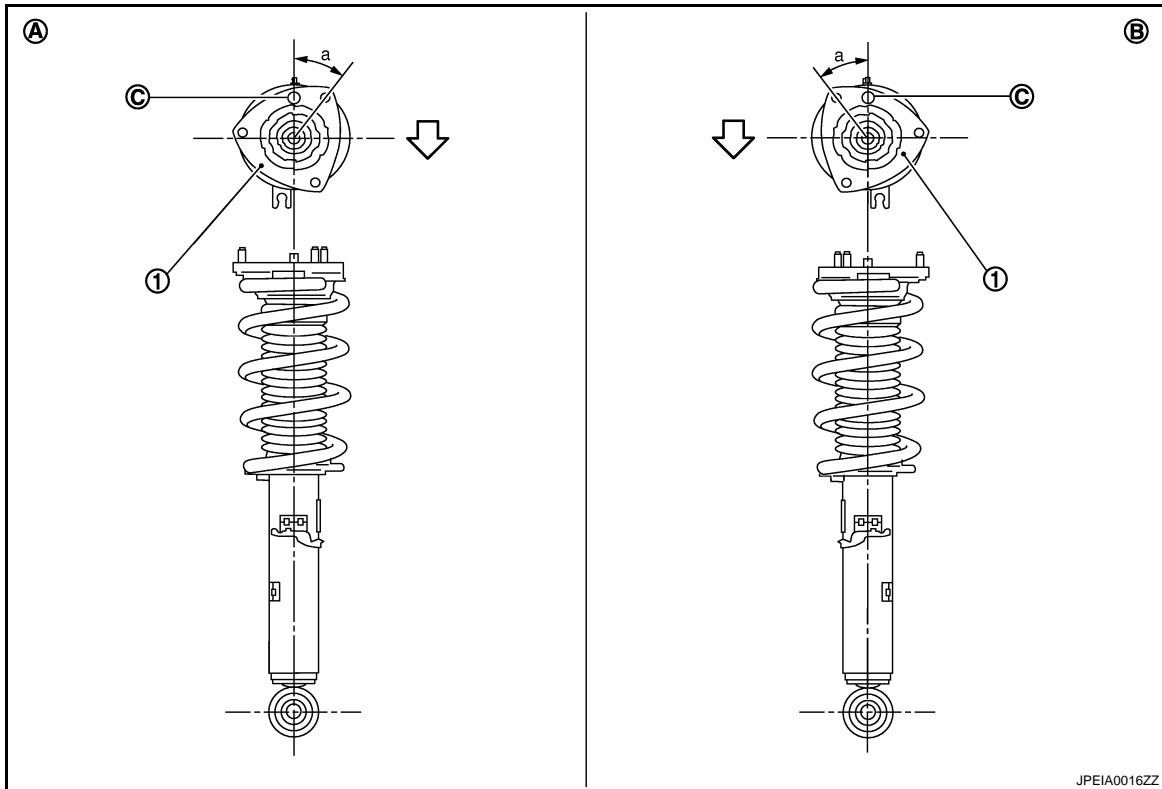

1. Shock absorber mounting bracket

A. Right side

B. Left side

C. Coil spring lower end position

⇨ : Vehicle front

- Install the shock absorber mounting bracket as shown in the figure.

**Angle (a) : 35.4°**

- Check that the lower end of the coil spring is positioned at the spring lower seat of the shock absorber.

6. Secure piston rod tip so that piston rod does not turn, then tighten piston rod lock nut with specified torque.
7. Gradually release a spring compressor, and remove coil spring.

**CAUTION:**

**Loosen while making sure coil spring attachment position does not move.**

8. Remove the shock absorber attachment from shock absorber.
9. Install the mounting seal to shock absorber mounting bracket.

## Inspection

INFOID:000000005655661

### INSPECTION AFTER DISASSEMBLY

#### Shock Absorber

Check the following items, and replace the part if necessary.

- Shock absorber for deformation, cracks or damage.
- Piston rod for damage, uneven wear or distortion.
- Oil leakage.

#### Shock Absorber Mounting Bracket and Rubber Parts Inspection

Check shock absorber mounting bracket for cracks and rubber parts for wear. Replace it if necessary.

#### Coil Spring

Check coil spring for cracks, wear or damage, and replace it if necessary.

# FRONT COIL SPRING AND SHOCK ABSORBER

< REMOVAL AND INSTALLATION >

[2WD]

## INSPECTION AFTER INSTALLATION

- Check wheel sensor harness for proper connection. Refer to [BRC-103, "Exploded View"](#).
- Check wheel alignment. Refer to [FSU-8, "Inspection"](#).
- Adjust neutral position of steering angle sensor. Refer to [BRC-8, "ADJUSTMENT OF STEERING ANGLE SENSOR NEUTRAL POSITION : Special Repair Requirement"](#).

## Disposal

INFOID:000000005853425

1. Set shock absorber horizontally with the piston rod fully extended.
2. Drill 2 – 3 mm (0.08 – 0.12 in) hole at the position (●) from top as shown in the figure to release gas gradually.

### CAUTION:

- **Wear eye protection (safety glasses).**
- **Wear gloves.**
- **Be careful with metal chips or oil blown out by the compressed gas.**

### NOTE:

- Drill vertically in this direction (←).
- Directly to the outer tube avoiding brackets.
- The gas is clear, colorless, odorless, and harmless.

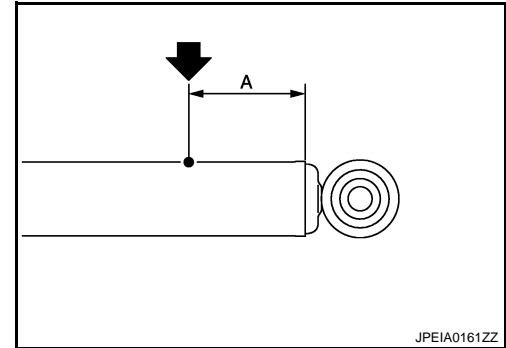

**A : 20 – 30 mm (0.79 – 1.18 in)**

3. Position the drilled hole downward and drain oil by moving the piston rod several times.

### CAUTION:

**Dispose of drained oil according to the law and local regulations.**

# TRANSVERSE LINK

< REMOVAL AND INSTALLATION >

[2WD]

## TRANSVERSE LINK

Exploded View

INFOID:000000005655662

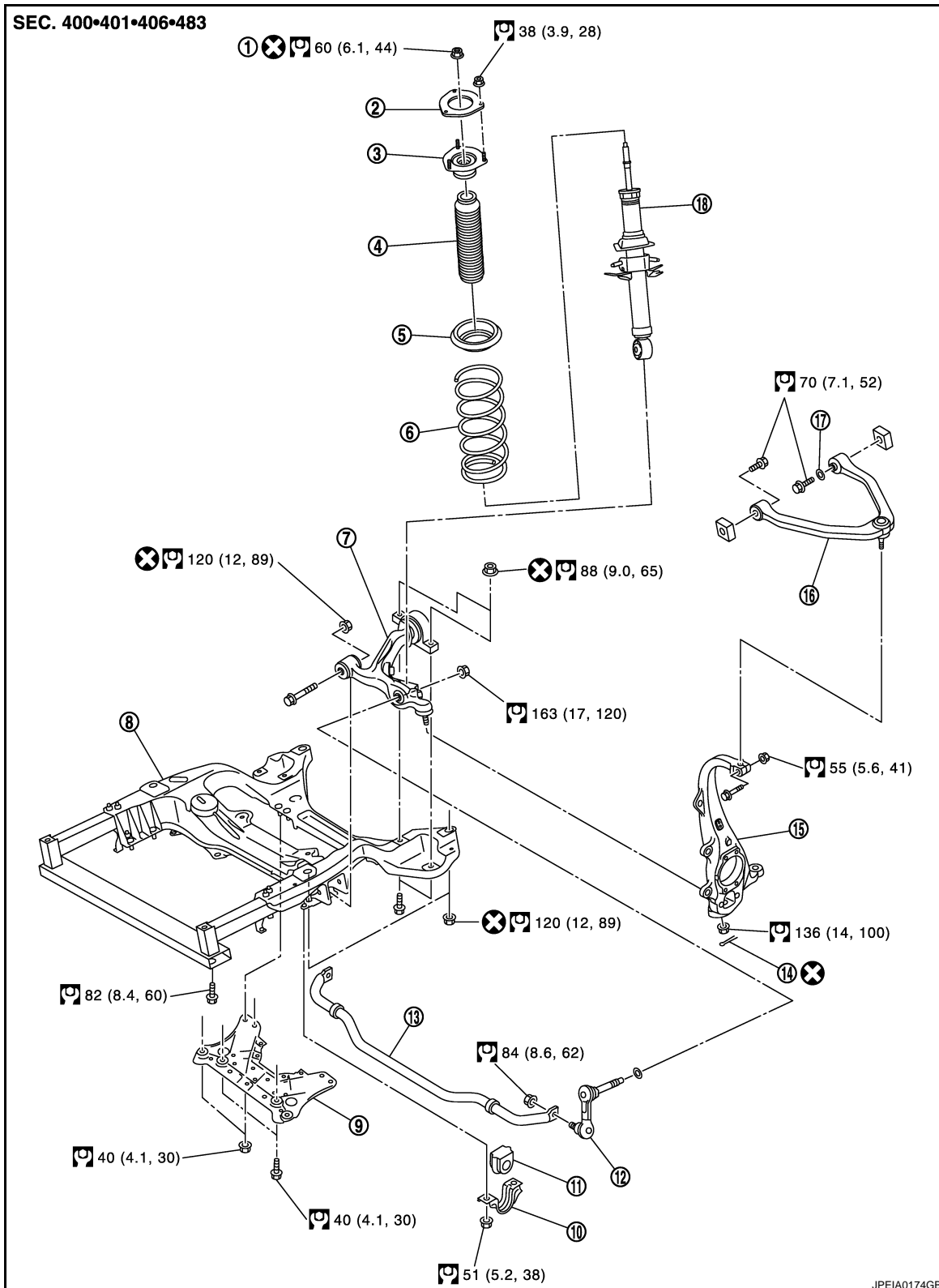

- |                        |                            |                                    |
|------------------------|----------------------------|------------------------------------|
| 1. Piston rod lock nut | 2. Mounting seal           | 3. Shock absorber mounting bracket |
| 4. Bound bumper        | 5. Rubber seat             | 6. Coil spring                     |
| 7. Transverse link     | 8. Front suspension member | 9. Suspension member stay          |

# TRANSVERSE LINK

## < REMOVAL AND INSTALLATION >

[2WD]

- |                      |                        |                               |
|----------------------|------------------------|-------------------------------|
| 10. Stabilizer clamp | 11. Stabilizer bushing | 12. Stabilizer connecting rod |
| 13. Stabilizer bar   | 14. Cotter pin         | 15. Steering knuckle          |
| 16. Upper link       | 17. Stopper rubber     | 18. Shock absorber            |

Refer to [GI-4, "Components"](#) for symbols in the figure.

## Removal and Installation

INFOID:000000005655663

### REMOVAL

1. Remove tires with power tool.
2. Remove under cover with power tool.
3. Remove shock absorber. Refer to [FSU-9, "Exploded View"](#).
4. Remove steering outer socket from steering knuckle. Refer to [ST-30, "2WD : Exploded View"](#).
5. Remove transverse link from steering knuckle.
6. Set suitable jack under transverse link.
7. Remove mounting bolts and nuts, and then remove transverse link.

### INSTALLATION

Note the following, and install in the reverse order of removal.

- Never tap on the ball joint cap of the stabilizer connecting rod with a hammer or a similar item when inserting the stabilizer connecting rod into the transverse link.
- Perform final tightening of bolts and nuts at the front suspension member installation and shock absorber lower side (rubber bushing), under unladen conditions with tires on level ground.
- Never reuse cotter pin.

### Inspection

INFOID:000000005655664

### INSPECTION AFTER REMOVAL

#### Appearance

Check the following items, and replace the part if necessary.

- Transverse link and bushing for deformation, cracks or damage.
- Ball joint boot for cracks or other damage, and also for grease leakage.

#### Ball Joint Inspection

Manually move ball stud to confirm it moves smoothly with no binding.

#### Swing Torque Inspection

##### NOTE:

Before measurement, move ball stud at least ten times by hand to check for smooth movement.

- Hook a spring balance (A) at cotter pin mounting hole. Confirm spring balance measurement value is within specifications when ball stud begins moving.

#### Standard

#### Swing torque

: Refer to [FSU-23, "Ball Joint"](#).

- If it is outside the specified range, replace transverse link assembly.

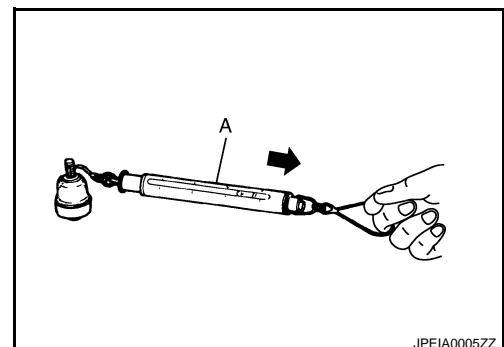

#### Rotating Torque Inspection

## TRANSVERSE LINK

[2WD]

### < REMOVAL AND INSTALLATION >

- Attach mounting nut to ball stud. Make sure that rotating torque is within specifications with a preload gauge (A) [SST: ST3127S000 (J-25765-A)].

#### Standard

**Rotating torque** : Refer to [FSU-23, "Ball Joint"](#).

- If it is outside the specified range, replace transverse link assembly.

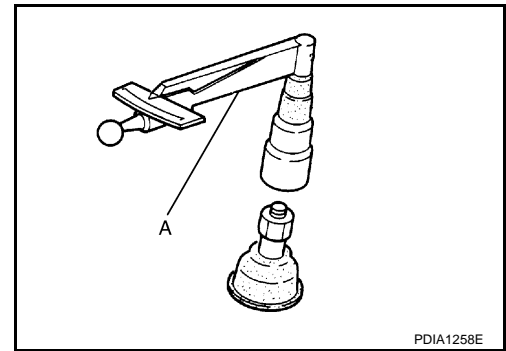

#### Axial End Play Inspection

- Move tip of ball stud in axial direction to check for looseness.

#### Standard

**Axial end play** : Refer to [FSU-23, "Ball Joint"](#).

- If it is outside the specified range, replace transverse link assembly.

### INSPECTION AFTER INSTALLATION

- Check wheel sensor harness for proper connection. Refer to [BR-21, "FRONT : Exploded View"](#).
- Check wheel alignment. Refer to [FSU-8, "Inspection"](#).
- Adjust neutral position of steering angle sensor. Refer to [BRC-8, "ADJUSTMENT OF STEERING ANGLE SENSOR NEUTRAL POSITION : Special Repair Requirement"](#).



# UPPER LINK

< REMOVAL AND INSTALLATION >

[2WD]

## UPPER LINK

Exploded View

INFOID:000000005655665

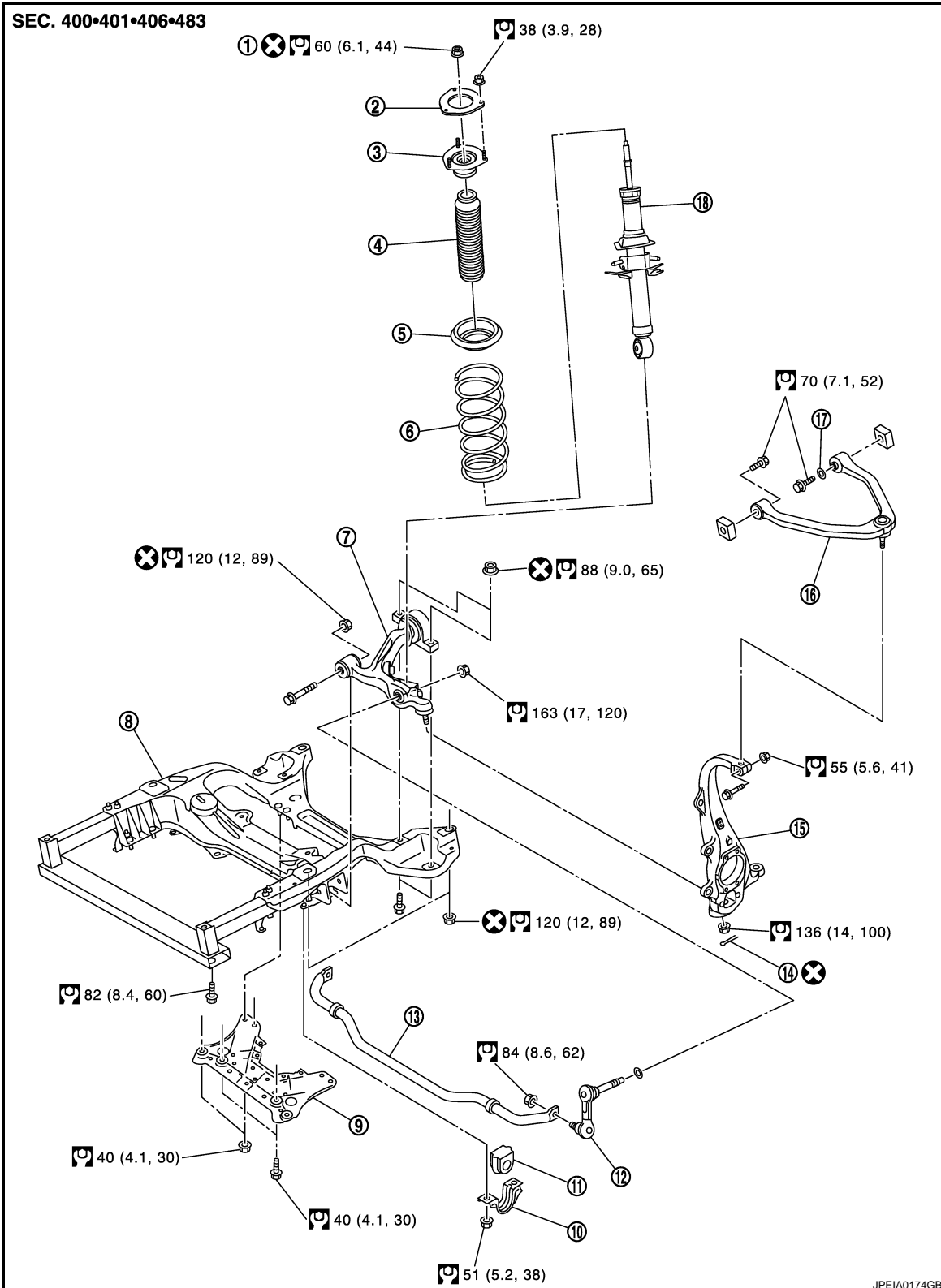

- |                        |                            |                                    |
|------------------------|----------------------------|------------------------------------|
| 1. Piston rod lock nut | 2. Mounting seal           | 3. Shock absorber mounting bracket |
| 4. Bound bumper        | 5. Rubber seat             | 6. Coil spring                     |
| 7. Transverse link     | 8. Front suspension member | 9. Suspension member stay          |

# UPPER LINK

## < REMOVAL AND INSTALLATION >

[2WD]

- |                      |                        |                               |
|----------------------|------------------------|-------------------------------|
| 10. Stabilizer clamp | 11. Stabilizer bushing | 12. Stabilizer connecting rod |
| 13. Stabilizer bar   | 14. Cotter pin         | 15. Steering knuckle          |
| 16. Upper link       | 17. Stopper rubber     | 18. Shock absorber            |
- Refer to [GI-4, "Components"](#) for symbols in the figure.

## Removal and Installation

INFOID:000000005655666

### REMOVAL

1. Remove tires with power tool.
2. Remove shock absorber. Refer to [FSU-9, "Exploded View"](#).
3. Remove mounting bolts and nuts with power tool, and then remove upper link from steering knuckle.
4. Remove mounting bolts and nuts, and then remove upper link and stopper rubber.

### INSTALLATION

Note the following, and install in the reverse order of removal.

- Perform final tightening of bolts and nuts at the vehicle installation position (rubber bushing), under unladen conditions with tires on level ground.

### Inspection

INFOID:000000005655667

### INSPECTION AFTER REMOVAL

#### Appearance

Check the following items, and replace the part if necessary.

- Upper link and bushing for deformation, cracks or damage.
- Ball joint boot for cracks or other damage, and also for grease leakage.

#### Ball Joint Inspection

Manually move ball stud to confirm it moves smoothly with no binding.

#### Swing Torque Inspection

##### NOTE:

Before measurement, move ball stud at least ten times by hand to check for smooth movement.

- Hook a spring balance (A) at cutout on ball stud. Confirm spring balance measurement value is within specifications when ball stud begins moving.

#### Standard

**Swing torque** : Refer to [FSU-23, "Ball Joint"](#).

- If it is outside the specified range, replace upper link assembly.

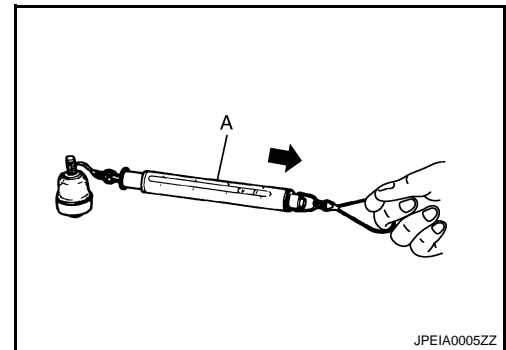

#### Axial End Play Inspection

- Move tip of ball stud in axial direction to check for looseness.

#### Standard

**Axial end play** : Refer to [FSU-23, "Ball Joint"](#).

- If it is outside the specified range, replace upper link assembly.

### INSPECTION AFTER INSTALLATION

- Check wheel sensor harness for proper connection. Refer to [BR-21, "FRONT : Exploded View"](#).
- Check wheel alignment. Refer to [FSU-8, "Inspection"](#).
- Adjust neutral position of steering angle sensor. Refer to [BRC-8, "ADJUSTMENT OF STEERING ANGLE SENSOR NEUTRAL POSITION : Special Repair Requirement"](#).



# FRONT STABILIZER

## < REMOVAL AND INSTALLATION >

[2WD]

- |                      |                        |                               |
|----------------------|------------------------|-------------------------------|
| 10. Stabilizer clamp | 11. Stabilizer bushing | 12. Stabilizer connecting rod |
| 13. Stabilizer bar   | 14. Cotter pin         | 15. Steering knuckle          |
| 16. Upper link       | 17. Stopper rubber     | 18. Shock absorber            |

Refer to [GI-4. "Components"](#) for symbols in the figure.

## Removal and Installation

INFOID:000000005655669

### REMOVAL

1. Remove tires with power tool.
2. Remove under cover with power tool.
3. Remove stabilizer connecting rod.

#### **CAUTION:**

**Apply a matching mark to identify the installation position.**

4. Remove the stabilizer clamp and stabilizer bushing.
5. Remove stabilizer bar.

### INSTALLATION

Note the following, and install in the reverse order of removal.

- Check the mounting mark when installing.
- Tighten the mounting nut to the specified torque while holding a hexagonal part of stabilizer connecting rod side.

## Inspection

INFOID:000000005655670

### INSPECTION AFTER REMOVAL

Check stabilizer bar, stabilizer connecting rod, stabilizer bushing and stabilizer clamp for deformation, cracks or damage. Replace it if a malfunction is detected.

# FRONT SUSPENSION MEMBER

< UNIT REMOVAL AND INSTALLATION >

[2WD]

## UNIT REMOVAL AND INSTALLATION

### FRONT SUSPENSION MEMBER

Exploded View

INFOID:000000005655671

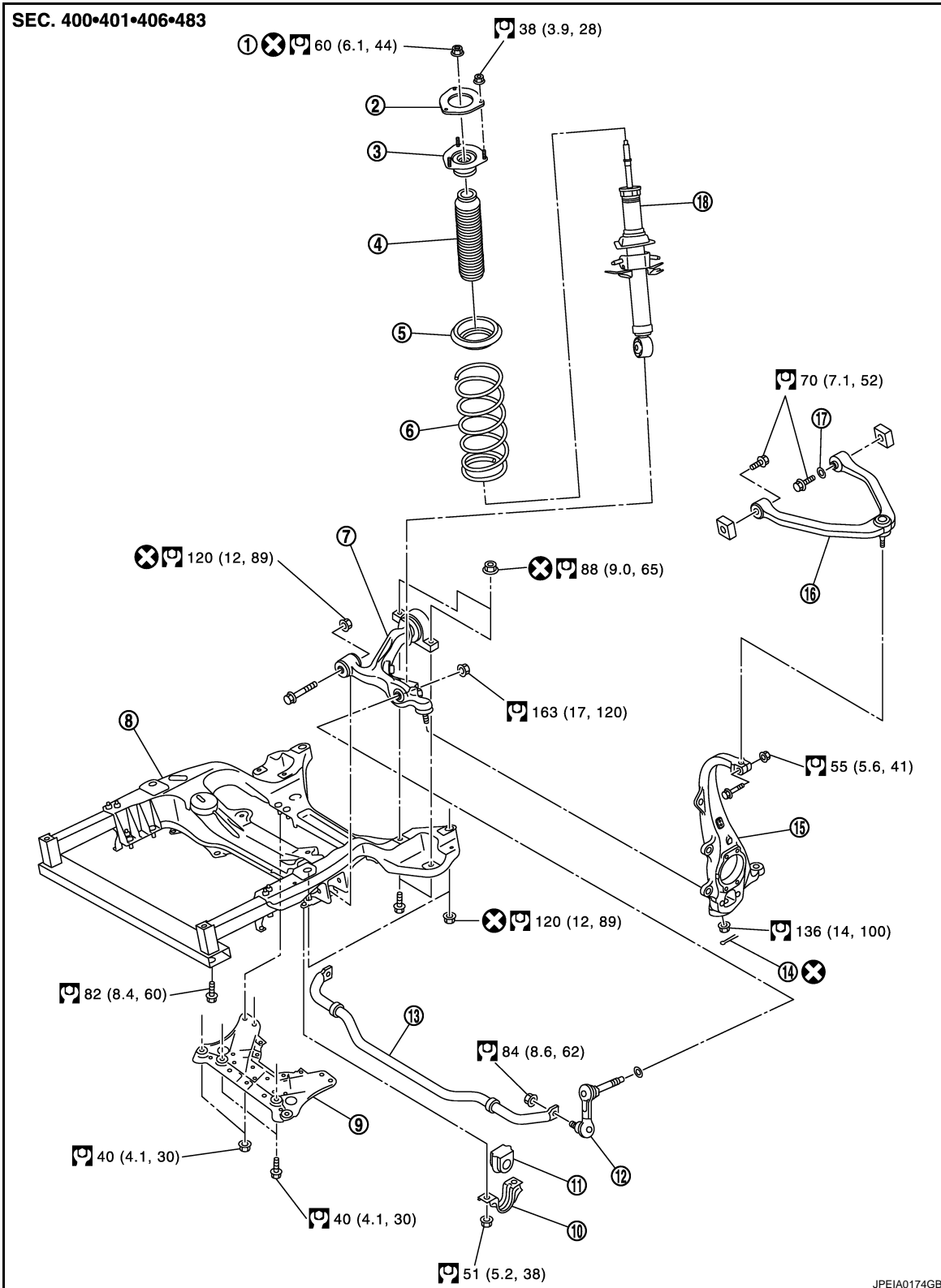

A  
B  
C  
D  
E  
F  
G  
H  
I  
J  
K  
L  
M  
N  
O  
P

FSU

# FRONT SUSPENSION MEMBER

< UNIT REMOVAL AND INSTALLATION >

[2WD]

- |                        |                            |                                    |
|------------------------|----------------------------|------------------------------------|
| 1. Piston rod lock nut | 2. Mounting seal           | 3. Shock absorber mounting bracket |
| 4. Bound bumper        | 5. Rubber seat             | 6. Coil spring                     |
| 7. Transverse link     | 8. Front suspension member | 9. Suspension member stay          |
| 10. Stabilizer clamp   | 11. Stabilizer bushing     | 12. Stabilizer connecting rod      |
| 13. Stabilizer bar     | 14. Cotter pin             | 15. Steering knuckle               |
| 16. Upper link         | 17. Stopper rubber         | 18. Shock absorber                 |

Refer to [GI-4, "Components"](#) for symbols in the figure.

## Removal and Installation

INFOID:000000005655672

### REMOVAL

1. Remove tire with power tool.
2. Remove under cover with power tool.
3. Remove suspension member stay with power tool.
4. Separate steering gear assembly and lower joint. Refer to [ST-24, "WITHOUT 4WAS : Exploded View"](#) (without 4WAS), [ST-25, "WITH 4WAS : Exploded View"](#) (with 4WAS).
5. Remove steering outer socket from steering knuckle. Refer to [ST-30, "2WD : Exploded View"](#).
6. Remove wheel sensor from steering knuckle. Refer to [BRC-103, "Exploded View"](#).
7. Remove stabilizer connecting rod from transverse link. Refer to [FSU-19, "Exploded View"](#).
8. Remove front stabilizer. Refer to [FSU-19, "Exploded View"](#).
9. Install engine slinger, and then hoist engine. Refer to [EM-69, "2WD : Removal and Installation"](#).
10. Remove transverse link from front suspension member. Refer to [FSU-14, "Exploded View"](#).
11. Remove steering hydraulic piping bracket and steering gear from front suspension member. Refer to [ST-59, "2WD : Exploded View"](#).
12. Set suitable jack front suspension member.
13. Remove mounting nuts between engine mounting insulator and from suspension member. Refer to [EM-69, "2WD : Exploded View"](#).
14. Remove mounting bolts and nuts of front suspension member with power tool.
15. Gradually lower jack to remove front suspension assembly from vehicle.

### INSTALLATION

Note the following, and install in the reverse order of removal.

- Perform final tightening of installation position between front suspension member and transverse links (rubber bushing) under unladen condition with tires on level ground.

### Inspection

INFOID:000000005655673

#### INSPECTION AFTER REMOVAL

Check the front suspension member for significant deformation, cracks, or damages. Replace if necessary.

#### INSPECTION AFTER INSTALLATION

- Check wheel sensor harness for proper connection. Refer to [BR-21, "FRONT : Exploded View"](#).
- Check wheel alignment. Refer to [FSU-8, "Inspection"](#).
- Adjust the neutral position of the steering angle sensor. Refer to [BRC-8, "ADJUSTMENT OF STEERING ANGLE SENSOR NEUTRAL POSITION : Special Repair Requirement"](#).

# SERVICE DATA AND SPECIFICATIONS (SDS)

< SERVICE DATA AND SPECIFICATIONS (SDS)

[2WD]

## SERVICE DATA AND SPECIFICATIONS (SDS)

### SERVICE DATA AND SPECIFICATIONS (SDS)

#### Wheel Alignment

INFOID:0000000005655674

Item		Standard	
Camber Degree minute (Decimal degree)	Minimum	-1° 10' (-1.17°)	
	Nominal	-0° 25' (-0.42°)	
	Maximum	0° 20' (0.33°)	
	Left and right difference	0° 33' (0.55°) or less	
Caster Degree minute (Decimal degree)	Minimum	4° 05' (4.08°)	
	Nominal	4° 50' (4.83°)	
	Maximum	5° 35' (5.58°)	
	Left and right difference	0° 39' (0.65°) or less	
Kingpin inclination Degree minute (Decimal degree)	Minimum	6° 40' (6.67°)	
	Nominal	7° 25' (7.42°)	
	Maximum	8° 10' (8.17°)	
Total toe-in	Distance	Minimum	0 mm (0 in)
		Nominal	In 1 mm (0.04 in)
		Maximum	In 2 mm (0.08 in)
	Angle (left wheel or right wheel) Degree minute (Decimal Degree)	Minimum	0° 00' (0.00°)
		Nominal	In 0° 02' 30" (0.04°)
		Maximum	In 0° 05' (0.08°)

Measure value under unladen\* conditions.

\*: Fuel, engine coolant and lubricant are full. Spare tire, jack, hand tools and mats are in designated positions.

#### Ball Joint

INFOID:0000000005655675

Item		Standard
Swing torque	Transverse link	0.5 – 3.6 N·m (0.06 – 0.36 kg·m, 5 – 31 in-lb)
	Upper link	0 – 2.0 N·m (0 – 0.2 kg·m, 0 – 17 in-lb)
Measurement on spring balance	Transverse link	7.8 – 56.3 N (0.8 – 5.7 kg, 1.8 – 12.7 lb)
	Upper link	0 – 61.5 N (0 – 6.3 kg, 0 – 13.8 lb)
Rotating torque	Transverse link	0.5 – 3.9 N·m (0.06 – 0.39 kg·m, 5 – 34 in-lb)
Axial end play		0 mm (0 in)

#### Wheelarch Height

INFOID:0000000005655676

Item	Standard		
	Except for sports models		For sports models
Wheel size	18 inch	19 inch	
Front (Hf)	712 mm (28.03 in)	715 mm (28.15 in)	716 mm (28.19 in)

# SERVICE DATA AND SPECIFICATIONS (SDS)

< SERVICE DATA AND SPECIFICATIONS (SDS)

[2WD]

Item	Standard		
	Except for sports models		For sports models
Applied model			
Wheel size	18 inch	19 inch	
Rear (Hr)	702 mm (27.64 in)	705 mm (27.76 in)	706 mm (27.80 in)

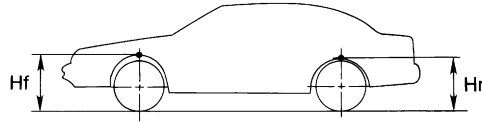

SFA818A

Measure value under unladen\* conditions

\*: Fuel, engine coolant and lubricant are full. Spare tire, jack, hand tools and mats are in designated positions.



# NOISE, VIBRATION AND HARSHNESS (NVH) TROUBLESHOOTING

< SYMPTOM DIAGNOSIS >

[AWD]

## SYMPTOM DIAGNOSIS

### NOISE, VIBRATION AND HARSHNESS (NVH) TROUBLESHOOTING

#### NVH Troubleshooting Chart

INFOID:000000005655677

Use chart below to find the cause of the symptom. If necessary, repair or replace these parts.

Symptom	FRONT SUSPENSION	Possible cause and SUSPECTED PARTS														Reference page		
		Improper installation, looseness	Shock absorber deformation, damage or deflection	Bushing or mounting deterioration	Parts interference	Spring fatigue	Suspension looseness	Incorrect wheel alignment	Stabilizer bar fatigue	PROPELLER SHAFT	DIFFERENTIAL	FRONT AXLE AND FRONT SUSPENSION	TIRE	ROAD WHEEL	DRIVE SHAFT		BRAKE	STEERING
Noise		x	x	x	x	x	x			x	x	x	x	x	x	x		FSU-31, FSU-36, FSU-39, FSU-41, FSU-43
Shake		x	x	x	x		x			x		x	x	x	x	x		FSU-35
Vibration		x	x	x	x	x				x		x	x		x			FSU-31, FSU-36, FSU-39, FSU-41, FSU-43
Shimmy		x	x	x	x			x				x	x	x		x		FSU-30
Judder		x	x	x									x	x		x	x	FSU-42
Poor quality ride or handling		x	x	x	x	x		x	x			x	x	x				NVH in DLN section. NVH in RFD section. NVH in FAX and FSU sections. NVH in WT section. NVH in WT section. NVH in FAX section. NVH in BR section. NVH in ST section.

x: Applicable

A  
B  
C  
D  
E  
F  
G  
H  
I  
J  
K  
L  
M  
N  
O  
P

FSU

## PRECAUTION

### PRECAUTIONS

#### Precaution for Supplemental Restraint System (SRS) "AIR BAG" and "SEAT BELT PRE-TENSIONER"

INFOID:000000005853499

The Supplemental Restraint System such as "AIR BAG" and "SEAT BELT PRE-TENSIONER", used along with a front seat belt, helps to reduce the risk or severity of injury to the driver and front passenger for certain types of collision. This system includes seat belt switch inputs and dual stage front air bag modules. The SRS system uses the seat belt switches to determine the front air bag deployment, and may only deploy one front air bag, depending on the severity of a collision and whether the front occupants are belted or unbelted. Information necessary to service the system safely is included in the "SRS AIR BAG" and "SEAT BELT" of this Service Manual.

**WARNING:**

- To avoid rendering the SRS inoperative, which could increase the risk of personal injury or death in the event of a collision which would result in air bag inflation, all maintenance must be performed by an authorized NISSAN/INFINITI dealer.
- Improper maintenance, including incorrect removal and installation of the SRS, can lead to personal injury caused by unintentional activation of the system. For removal of Spiral Cable and Air Bag Module, see the "SRS AIR BAG".
- Do not use electrical test equipment on any circuit related to the SRS unless instructed to in this Service Manual. SRS wiring harnesses can be identified by yellow and/or orange harnesses or harness connectors.

#### PRECAUTIONS WHEN USING POWER TOOLS (AIR OR ELECTRIC) AND HAMMERS

**WARNING:**

- When working near the Air Bag Diagnosis Sensor Unit or other Air Bag System sensors with the ignition ON or engine running, DO NOT use air or electric power tools or strike near the sensor(s) with a hammer. Heavy vibration could activate the sensor(s) and deploy the air bag(s), possibly causing serious injury.
- When using air or electric power tools or hammers, always switch the ignition OFF, disconnect the battery, and wait at least 3 minutes before performing any service.

#### Precaution Necessary for Steering Wheel Rotation after Battery Disconnect

INFOID:000000005853646

**NOTE:**

- Before removing and installing any control units, first turn the push-button ignition switch to the LOCK position, then disconnect both battery cables.
- After finishing work, confirm that all control unit connectors are connected properly, then re-connect both battery cables.
- Always use CONSULT-III to perform self-diagnosis as a part of each function inspection after finishing work. If a DTC is detected, perform trouble diagnosis according to self-diagnosis results.

For vehicle with steering lock unit, if the battery is disconnected or discharged, the steering wheel will lock and cannot be turned.

If turning the steering wheel is required with the battery disconnected or discharged, follow the operation procedure below before starting the repair operation.

#### OPERATION PROCEDURE

1. Connect both battery cables.

**NOTE:**

Supply power using jumper cables if battery is discharged.

2. Turn the push-button ignition switch to ACC position.  
(At this time, the steering lock will be released.)
3. Disconnect both battery cables. The steering lock will remain released with both battery cables disconnected and the steering wheel can be turned.
4. Perform the necessary repair operation.

# PRECAUTIONS

[AWD]

## < PRECAUTION >

5. When the repair work is completed, re-connect both battery cables. With the brake pedal released, turn the push-button ignition switch from ACC position to ON position, then to LOCK position. (The steering wheel will lock when the push-button ignition switch is turned to LOCK position.)
6. Perform self-diagnosis check of all control units using CONSULT-III.

### Precaution for Procedure without Cowl Top Cover

INFOID:000000005853647

When performing the procedure after removing cowl top cover, cover the lower end of windshield with urethane, etc.

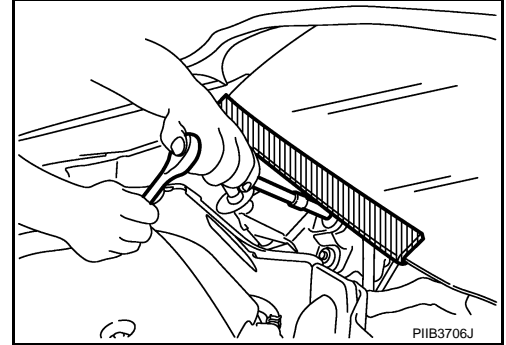

### Precautions for Suspension

INFOID:000000005655681

- When installing rubber bushings, the final tightening must be carried out under unladen conditions with tires on ground. Spilled oil might shorten the life of rubber bushings. Be sure to wipe off any spilled oil.
- Unladen conditions mean that fuel, engine coolant and lubricant are full. Spare tire, jack, hand tools and mats are in designated positions.
- After servicing suspension parts, be sure to check wheel alignment.
- Self-lock nuts are not reusable. Always use new ones when installing. Since new self-lock nuts are pre-oiled, tighten as they are.

# PREPARATION

< PREPARATION >

[AWD]

## PREPARATION

### PREPARATION

#### Special Service Tool

INFOID:000000005655682

The actual shapes of Kent-Moore tools may differ from those of special service tools illustrated here.

Tool number (Kent-Moore No.) Tool name	Description
ST35652000 ( - ) Shock absorber attachment	Disassembling and assembling shock absorber
ST3127S000 (J-25765-A) Preload gauge	Measuring rotating torque of ball joint

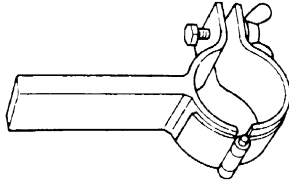

ZZA0807D

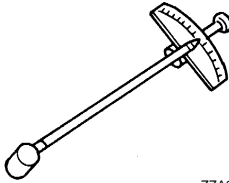

ZZA0806D

#### Commercial Service Tool

INFOID:000000005655683

Tool name	Description
Power tool	Loosening bolts and nuts
Spring compressor	Removing and installing coil spring

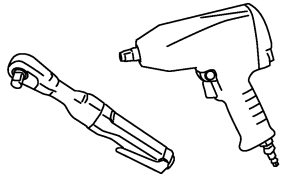

PBIC0190E

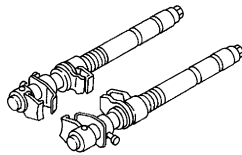

S-NT717

# FRONT SUSPENSION ASSEMBLY

< PERIODIC MAINTENANCE >

[AWD]

## PERIODIC MAINTENANCE

### FRONT SUSPENSION ASSEMBLY

#### Inspection

INFOID:000000005655684

#### MOUNTING INSPECTION

Make sure the mounting conditions (looseness, backlash) of each component and component conditions (wear, damage) are normal.

#### BALL JOINT AXIAL END PLAY

1. Set front wheels in a straight-ahead position.

**CAUTION:**

**Never depress brake pedal.**

2. Place an iron bar or equivalent between transverse link or upper link and steering knuckle.
3. Measure axial end play by prying it up and down.

**Standard**

**Axial end play** : Refer to [FSU-45, "Ball Joint"](#).

**CAUTION:**

**Be careful not to damage ball joint boot. never damage the installation position by applying excessive force.**

#### SHOCK ABSORBER

Check for oil leakage, damage and replace if malfunction is detected.

A  
B  
C  
D  
E  
F  
G  
H  
I  
J  
K  
L  
M  
N  
O  
P

FSU

## WHEEL ALIGNMENT

### Inspection

INFOID:000000005655685

### DESCRIPTION

#### CAUTION:

- **Camber, caster, kingpin inclination angles cannot be adjusted.**
- **If camber, caster, or kingpin inclination angle is outside the standard, check front suspension parts for wear and damage. Replace suspect parts if a malfunction is detected.**
- **Kingpin inclination angle is reference value, no inspection is required.**
- **Measure wheel alignment under unladen conditions.**

#### NOTE:

“Unladen conditions” means that fuel, engine coolant, and lubricant are full. Spare tire, jack, hand tools and mats are in designated positions.

### GENERAL INFORMATION AND RECOMMENDATIONS

- A four-wheel thrust alignment should be performed.
- This type of alignment is recommended for any NISSAN/INFINITI vehicle.
- The four-wheel “thrust” process helps ensure that the vehicle is properly aligned and the steering wheel is centered.
- The alignment rack itself should be capable of accepting any NISSAN/INFINITI vehicle.
- The rack should be checked to ensure that it is level.
- Make sure the machine is properly calibrated.
- Your alignment equipment should be regularly calibrated in order to give correct information.
- Check with the manufacturer of your specific equipment for their recommended Service/Calibration Schedule.

### ALIGNMENT PROCESS

#### IMPORTANT:

Use only the alignment specifications listed in this Service Manual.

- When displaying the alignment settings, many alignment machines use “indicators”: (Green/red, plus or minus, Go/No Go). **Never use these indicators.**
- The alignment specifications programmed into your machine that operate these indicators may not be correct.
- This may result in an ERROR.
- Some newer alignment machines are equipped with an optional “Rolling Compensation” method to “compensate” the sensors (alignment targets or head units). **Never use this “Rolling Compensation” method.**
- Use the “Jacking Compensation Method”. After installing the alignment targets or head units, raise the vehicle and rotate the wheels 1/2 turn both ways.
- See Instructions in the alignment machine you're using for more information on this.

### PRELIMINARY CHECK

Check the following:

- Tires for improper air pressure and wear.
- Road wheels for runout. Refer to [WT-56, "Inspection"](#).
- Wheel bearing axial end play. Refer to [FAX-18, "Inspection"](#).
- Transverse link or upper link ball joint axial end play. Refer to [FSU-37, "Inspection"](#), [FSU-40, "Inspection"](#).
- Shock absorber operation.
- Each mounting part of axle and suspension for looseness and deformation.
- Each of suspension member, shock absorber, upper link and transverse link for cracks, deformation and other damage.
- Vehicle height (posture).

# FRONT COIL SPRING AND SHOCK ABSORBER

< REMOVAL AND INSTALLATION >

[AWD]

## REMOVAL AND INSTALLATION

### FRONT COIL SPRING AND SHOCK ABSORBER

Exploded View

INFOID:000000005853920

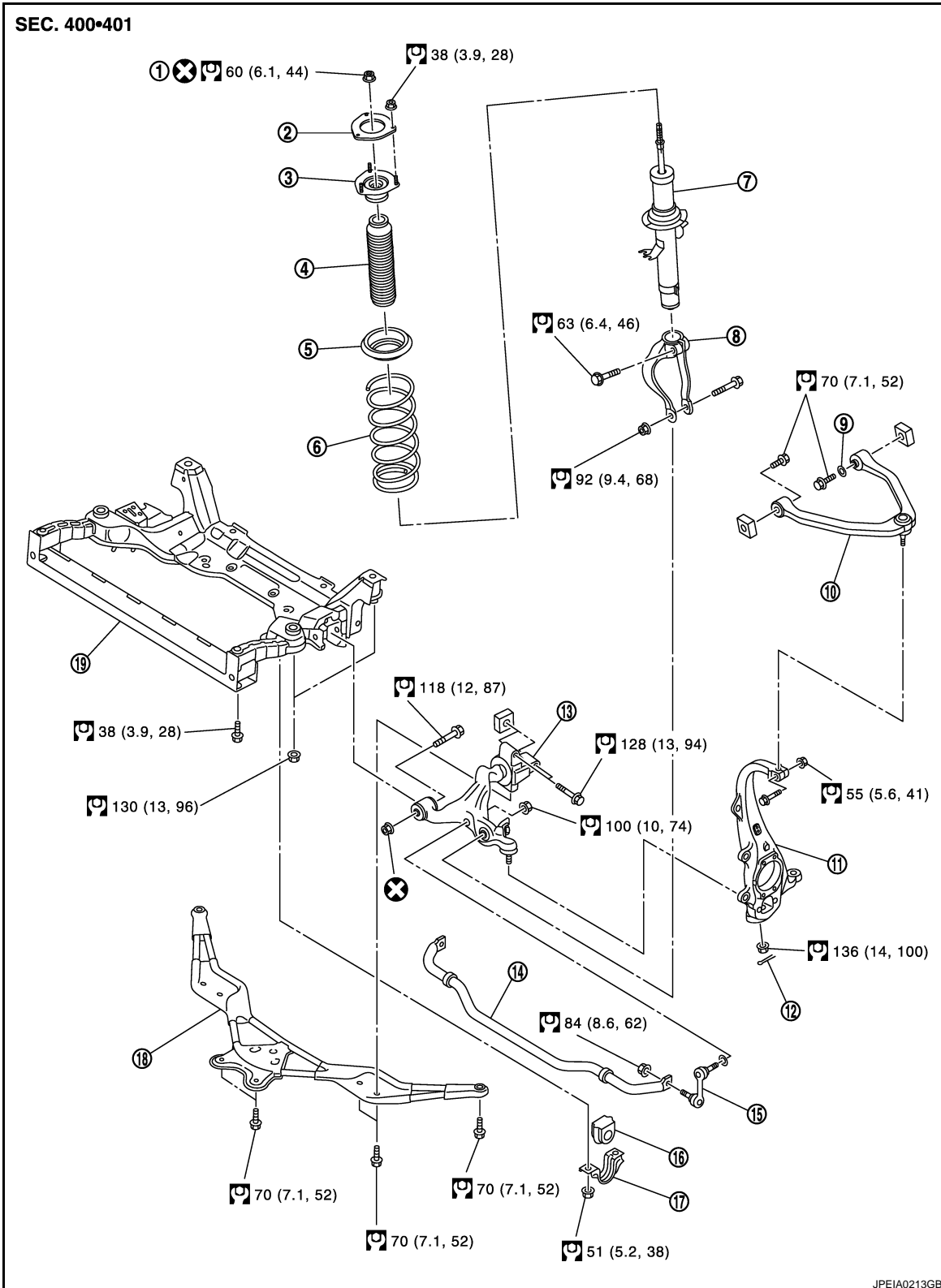

A

B

C

D

FSU

F

G

H

I

J

K

L

M

N

O

P

# FRONT COIL SPRING AND SHOCK ABSORBER

< REMOVAL AND INSTALLATION >

[AWD]

- |                             |                       |                                    |
|-----------------------------|-----------------------|------------------------------------|
| 1. Piston rod lock nut      | 2. Mounting seal      | 3. Shock absorber mounting bracket |
| 4. Bound bumper             | 5. Rubber seat        | 6. Coil spring                     |
| 7. Shock absorber           | 8. Shock absorber arm | 9. Stopper rubber                  |
| 10. Upper link              | 11. Steering knuckle  | 12. Cotter pin                     |
| 13. Transverse link         | 14. Stabilizer bar    | 15. Stabilizer connecting rod      |
| 16. Stabilizer bushing      | 17. Stabilizer clamp  | 18. Front cross bar                |
| 19. Front suspension member |                       |                                    |

Refer to [GI-4, "Components"](#) for symbols in the figure.

## Removal and Installation

INFOID:00000000565687

### REMOVAL

1. Remove tires with power tool.
2. Remove stabilizer connecting rod mounting nuts (upper side) with power tool, and then remove stabilizer connecting rod from transverse link.
3. Remove shock absorber mounting bolts and nuts (lower side) with power tool, and then remove shock absorber from transverse link.
4. Remove drive shaft. Refer to [FAX-23, "Exploded View"](#).
5. Separate upper link from steering knuckle.
6. Remove the mounting nuts of shock absorber mounting bracket, then remove shock absorber assembly.

### INSTALLATION

Note the following, and install in the reverse order of removal.

#### CAUTION:

**Never tap on the ball joint cap of the stabilizer connecting rod with a hammer or a similar item when inserting the stabilizer connecting rod into the transverse link.**

- Perform final tightening of bolts and nuts at the shock absorber lower side (rubber bushing), under unladen conditions with tires on level ground.

## Disassembly and Assembly

INFOID:00000000565688

### DISASSEMBLY

#### CAUTION:

**Never damage shock absorber piston rod when removing components from shock absorber.**

1. Remove the shock absorber arm from shock absorber.
2. Install shock absorber attachment (A) [SST: ST35652000 ( - )] to shock absorber and secure it in a vise.

#### CAUTION:

**When installing the shock absorbershock absorber attachment to shock absorber, wrap a shop cloth around shock absorber to protect it from damage.**

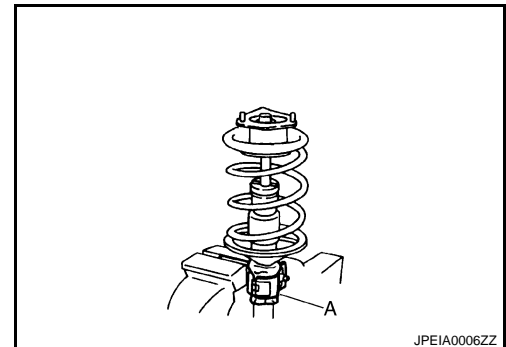

JPEIA0006ZZ



# FRONT COIL SPRING AND SHOCK ABSORBER

[AWD]

## < REMOVAL AND INSTALLATION >

- Using a spring compressor (A) (commercial service tool), compress coil spring between rubber seat and shock absorber until coil spring with a spring compressor is free.

**CAUTION:**

**Be sure a spring compressor is securely attached coil spring. Compress coil spring**

- Make sure coil spring with a spring compressor between rubber seat and shock absorber is free and then remove piston rod lock nut while securing the piston rod tip so that piston rod does not turn.

- Remove mounting seal, shock absorber mounting bracket, rubber seat, bound bumper from shock absorber.

- Remove coil spring with a spring compressor, and then gradually release a spring compressor.

**CAUTION:**

**Loosen while making sure coil spring attachment position does not move.**

- Remove the shock absorber attachment from shock absorber.

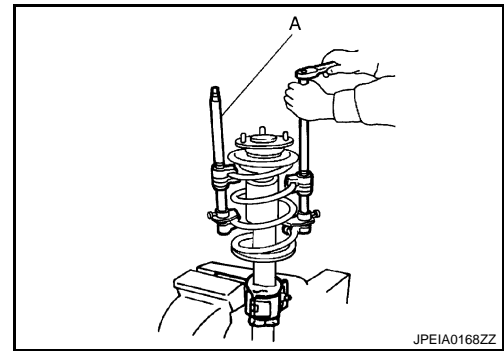

A  
B  
C  
D

FSU

## ASSEMBLY

- Install shock absorber attachment (A) [SST: ST35652000 ( - )] to shock absorber and secure it in a vise.

**CAUTION:**

**When installing the shock absorber attachment to shock absorber, wrap a shop cloth around shock absorber to protect it from damage.**

- Compress coil spring using a spring compressor (commercial service tool), and install it onto shock absorber.

**CAUTION:**

- Install with the large-diameter side (A) facing up and the small-diameter side (B) facing down.
- Be sure a spring compressor is securely attached to coil spring. Compress coil spring.

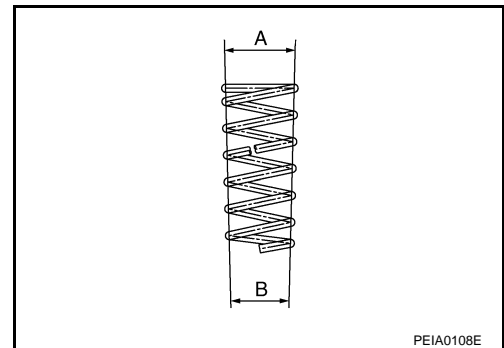

F  
G  
H  
I  
J  
K  
L

- Install the shock absorber mounting bracket and rubber seat.

**CAUTION:**

**Align the paint mark (A) to the stud bolt (1) position when assembling.**

- Apply soapy water to bound bumper.

**CAUTION:**

**Never use machine oil.**

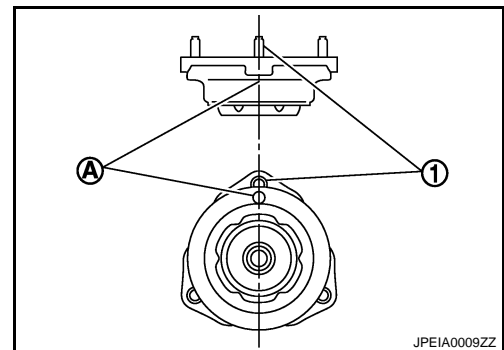

M  
N  
O  
P

# FRONT COIL SPRING AND SHOCK ABSORBER

< REMOVAL AND INSTALLATION >

[AWD]

5. Insert bound bumper into shock absorber mounting bracket, and then install it to shock absorber together with rubber seat.

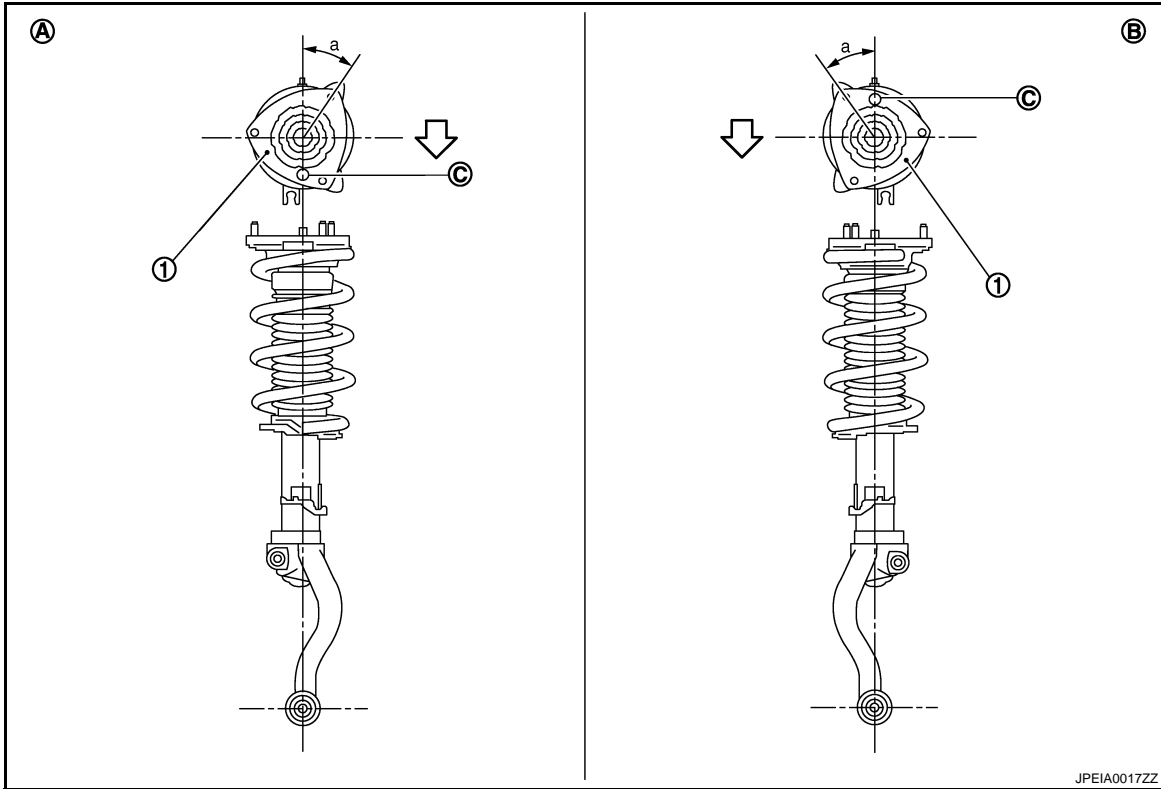

1. Shock absorber mounting bracket

A. Right side

B. Left side

C. Coil spring lower end position

⇐ : Vehicle front

- Install the shock absorber mounting bracket as shown in the figure.

**Angle (a) : 35.4°**

- Check that the lower end of the coil spring is positioned at the spring lower seat of the shock absorber.

6. Secure piston rod tip so that piston rod does not turn, then tighten piston rod lock nut with specified torque.
7. Gradually release a spring compressor, and remove coil spring.

**CAUTION:**

**Loosen while making sure coil spring attachment position does not move.**

8. Remove the shock absorber attachment from shock absorber.
9. Install the shock absorber arm to shock absorber.

**CAUTION:**

**To install, align the shock absorber protrusion (A) with the groove of shock absorber arm (1) and press it all the way to the locating bracket (B).**

10. Install the mounting seal to shock absorber mounting bracket.

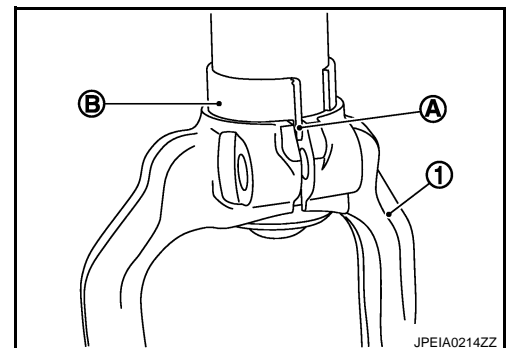

# FRONT COIL SPRING AND SHOCK ABSORBER

< REMOVAL AND INSTALLATION >

[AWD]

## Inspection

INFOID:000000005655689

### INSPECTION AFTER DISASSEMBLY

#### Shock Absorber

Check the following items, and replace the part if necessary.

- Shock absorber for deformation, cracks or damage.
- Piston rod for damage, uneven wear or distortion.
- Oil leakage.

#### Shock Absorber Mounting Bracket and Rubber Parts Inspection

Check shock absorber mounting bracket for cracks and rubber parts for wear. Replace it if necessary.

#### Coil Spring

Check coil spring for cracks, wear or damage, and replace it if necessary.

### INSPECTION AFTER INSTALLATION

1. Check wheel sensor harness for proper connection. Refer to [BRC-103, "Exploded View"](#).
2. Check wheel alignment. Refer to [FSU-30, "Inspection"](#).
3. Adjust neutral position of steering angle sensor. Refer to [BRC-8, "ADJUSTMENT OF STEERING ANGLE SENSOR NEUTRAL POSITION : Special Repair Requirement"](#).

## Disposal

INFOID:000000005853426

1. Set shock absorber horizontally with the piston rod fully extended.
2. Drill 2 – 3 mm (0.08 – 0.12 in) hole at the position (●) from top as shown in the figure to release gas gradually.

#### CAUTION:

- **Wear eye protection (safety glasses).**
- **Wear gloves.**
- **Be careful with metal chips or oil blown out by the compressed gas.**

#### NOTE:

- Drill vertically in this direction (←).
- Directly to the outer tube avoiding brackets.
- The gas is clear, colorless, odorless, and harmless.

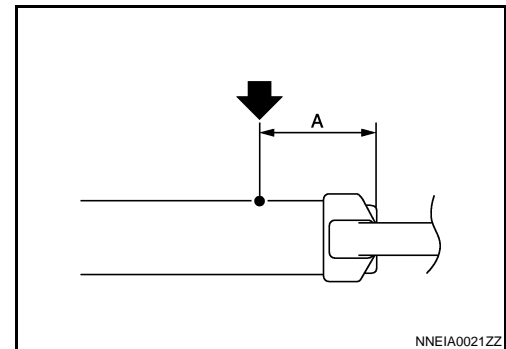

**A : 20 – 30 mm (0.79 – 1.18 in)**

3. Position the drilled hole downward and drain oil by moving the piston rod several times.

#### CAUTION:

**Dispose of drained oil according to the law and local regulations.**

# TRANSVERSE LINK

< REMOVAL AND INSTALLATION >

[AWD]

## TRANSVERSE LINK

Exploded View

INFOID:000000005853923

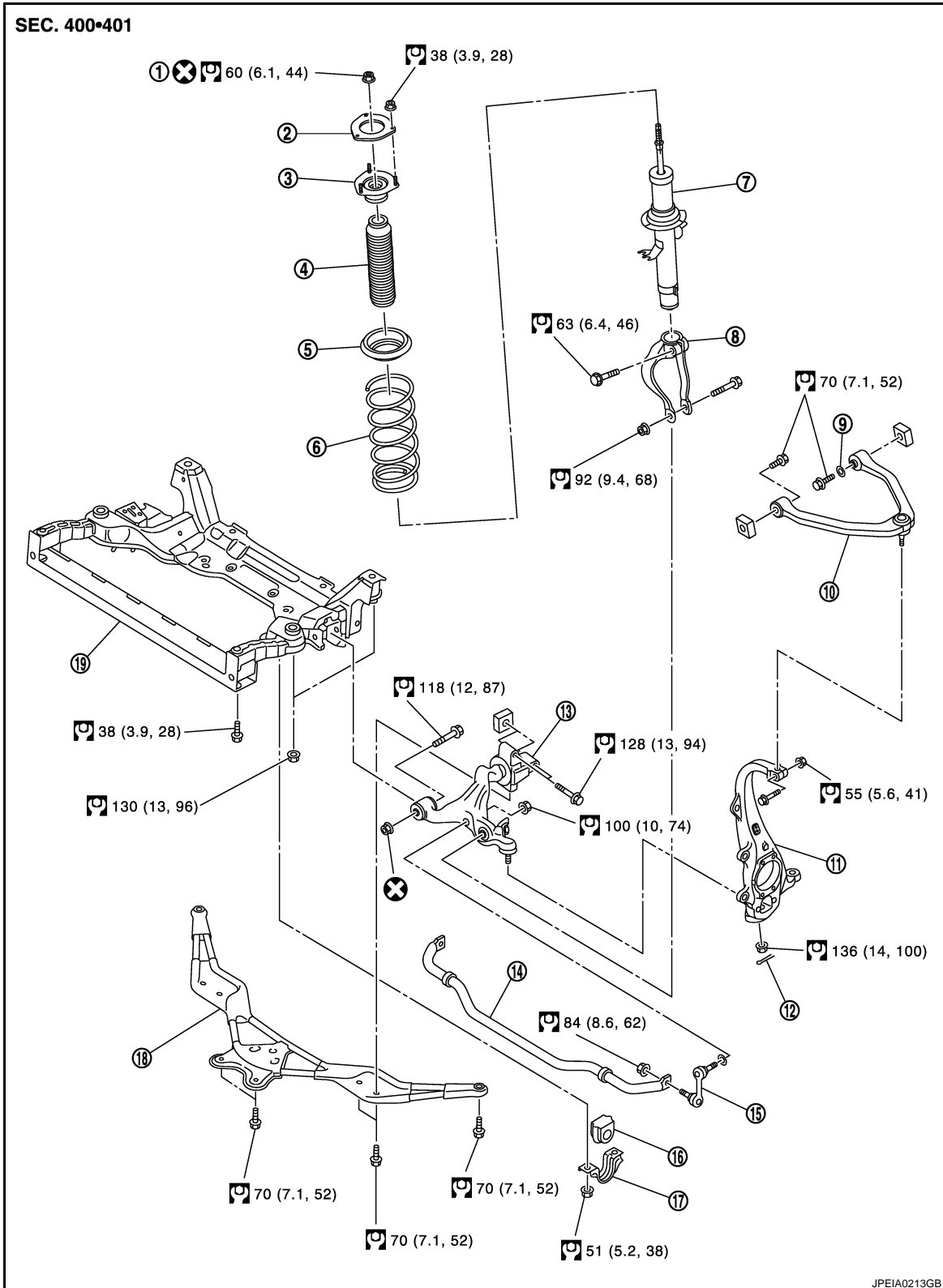

- |                        |                       |                                    |
|------------------------|-----------------------|------------------------------------|
| 1. Piston rod lock nut | 2. Mounting seal      | 3. Shock absorber mounting bracket |
| 4. Bound bumper        | 5. Rubber seat        | 6. Coil spring                     |
| 7. Shock absorber      | 8. Shock absorber arm | 9. Stopper rubber                  |

# TRANSVERSE LINK

[AWD]

## < REMOVAL AND INSTALLATION >

- |                             |                      |                               |
|-----------------------------|----------------------|-------------------------------|
| 10. Upper link              | 11. Steering knuckle | 12. Cotter pin                |
| 13. Transverse link         | 14. Stabilizer bar   | 15. Stabilizer connecting rod |
| 16. Stabilizer bushing      | 17. Stabilizer clamp | 18. Front cross bar           |
| 19. Front suspension member |                      |                               |

Refer to [GI-4, "Components"](#) for symbols in the figure.

## Removal and Installation

INFOID:000000005655691

### REMOVAL

1. Remove tires with power tool.
2. Remove under cover with power tool.
3. Remove shock absorber. Refer to [FSU-31, "Exploded View"](#).
4. Remove front crossbar.
5. Remove steering outer socket from steering knuckle. Refer to [ST-37, "AWD : Exploded View"](#).
6. Remove transverse link from steering knuckle.
7. Set suitable jack under transverse link.
8. Remove mounting bolts and nuts, and then remove transverse link.

### INSTALLATION

Note the following, and install in the reverse order of removal.

- Never tap on the ball joint cap of the stabilizer connecting rod with a hammer or a similar item when inserting the stabilizer connecting rod into the transverse link.
- Perform final tightening of bolts and nuts at the front suspension member installation and shock absorber lower side (rubber bushing), under unladen conditions with tires on level ground.

### Inspection

INFOID:000000005655692

#### INSPECTION AFTER REMOVAL

##### Appearance

Check the following items, and replace the part if necessary.

- Transverse link and bushing for deformation, cracks or damage.
- Ball joint boot for cracks or other damage, and also for grease leakage.

##### Ball Joint Inspection

Manually move ball stud to confirm it moves smoothly with no binding.

##### Swing Torque Inspection

###### NOTE:

Before measurement, move ball stud at least ten times by hand to check for smooth movement.

- Hook a spring balance (A) at cotter pin mounting hole. Confirm spring balance measurement value is within specifications when ball stud begins moving.

**Standard**

**Swing torque** :Refer to [FSU-45, "Ball Joint"](#).

- If it is outside the specified range, replace transverse link assembly.

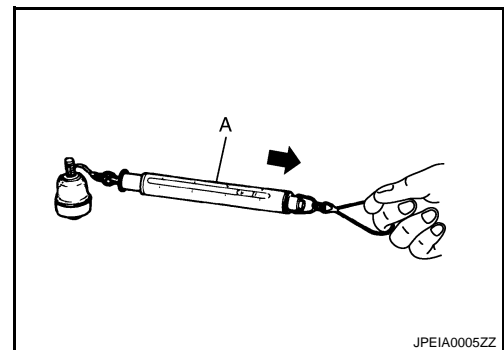

##### Rotating Torque Inspection

## TRANSVERSE LINK

[AWD]

### < REMOVAL AND INSTALLATION >

- Attach mounting nut to ball stud. Make sure that rotating torque is within specifications with a preload gauge (A) [SST: 3127S000 (J-25765-A)].

#### Standard

**Rotating torque** : Refer to [FSU-45, "Ball Joint"](#).

- If it is outside the specified range, replace transverse link assembly.

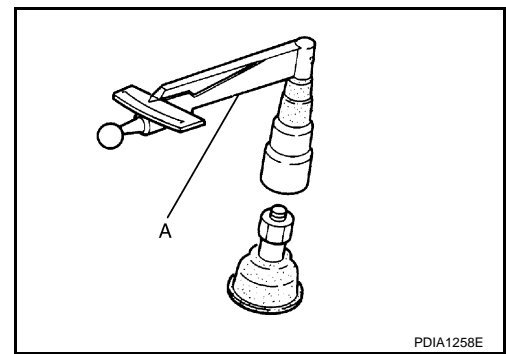

#### Axial End Play Inspection

- Move tip of ball stud in axial direction to check for looseness.

#### Standard

**Axial end play** : Refer to [FSU-45, "Ball Joint"](#).

- If it is outside the specified range, replace transverse link assembly.

### INSPECTION AFTER INSTALLATION

1. Check wheel sensor harness for proper connection. Refer to [BRC-103, "Exploded View"](#).
2. Check wheel alignment. Refer to [FSU-30, "Inspection"](#).
3. Adjust neutral position of steering angle sensor. Refer to [BRC-8, "ADJUSTMENT OF STEERING ANGLE SENSOR NEUTRAL POSITION : Special Repair Requirement"](#).

# UPPER LINK

< REMOVAL AND INSTALLATION >

[AWD]

## UPPER LINK

Exploded View

INFOID:000000005853924

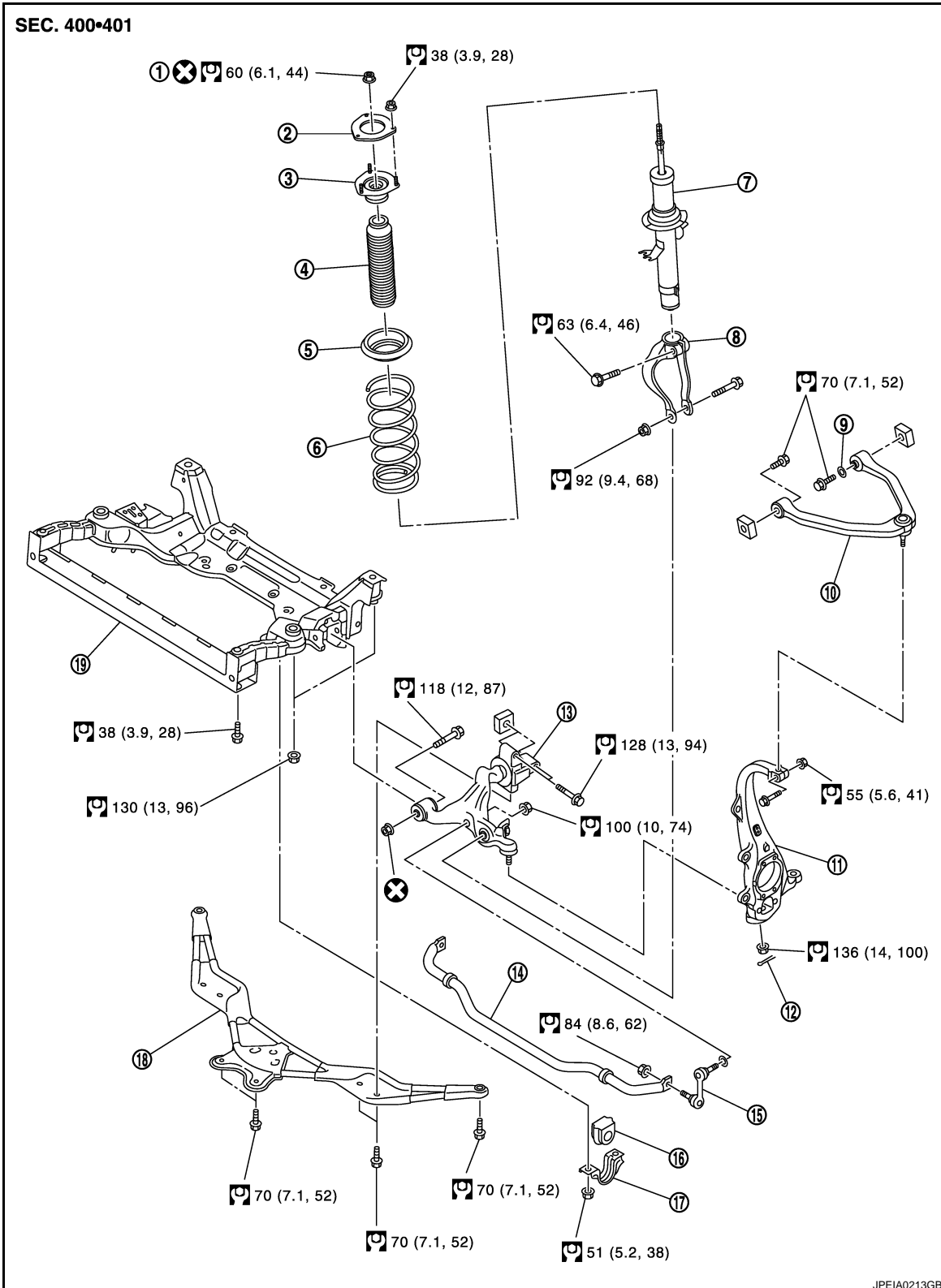

- |                        |                       |                                    |
|------------------------|-----------------------|------------------------------------|
| 1. Piston rod lock nut | 2. Mounting seal      | 3. Shock absorber mounting bracket |
| 4. Bound bumper        | 5. Rubber seat        | 6. Coil spring                     |
| 7. Shock absorber      | 8. Shock absorber arm | 9. Stopper rubber                  |

# UPPER LINK

## < REMOVAL AND INSTALLATION >

[AWD]

- |                             |                      |                               |
|-----------------------------|----------------------|-------------------------------|
| 10. Upper link              | 11. Steering knuckle | 12. Cotter pin                |
| 13. Transverse link         | 14. Stabilizer bar   | 15. Stabilizer connecting rod |
| 16. Stabilizer bushing      | 17. Stabilizer clamp | 18. Front cross bar           |
| 19. Front suspension member |                      |                               |

Refer to [GI-4, "Components"](#) for symbols in the figure.

## Removal and Installation

INFOID:00000000565694

### REMOVAL

1. Remove tires from with power tool.
2. Remove shock absorber. Refer to [FSU-31, "Exploded View"](#).
3. Remove mounting bolts and nuts with power tool, and then remove upper link from steering knuckle.
4. Remove mounting bolts and nuts, and then remove upper link and stopper rubber.

### INSTALLATION

Note the following, and install in the reverse order of removal.

- Perform final tightening of bolts and nuts at the vehicle installation position (rubber bushing), under unladen conditions with tires on level ground.

### Inspection

INFOID:00000000565695

#### INSPECTION AFTER REMOVAL

##### Appearance

Check the following items, and replace the part if necessary.

- Upper link and bushing for deformation, cracks or damage.
- Ball joint boot for cracks or other damage, and also for grease leakage.

##### Ball Joint Inspection

Manually move ball stud to confirm it moves smoothly with no binding.

##### Swing Torque Inspection

###### NOTE:

Before measurement, move ball stud at least ten times by hand to check for smooth movement.

- Hook a spring balance (A) at cutout on ball stud. Confirm spring balance measurement value is within specifications when ball stud begins moving.

##### Standard

**Swing torque** : Refer to [FSU-45, "Ball Joint"](#).

- If it is outside the specified range, replace upper link assembly.

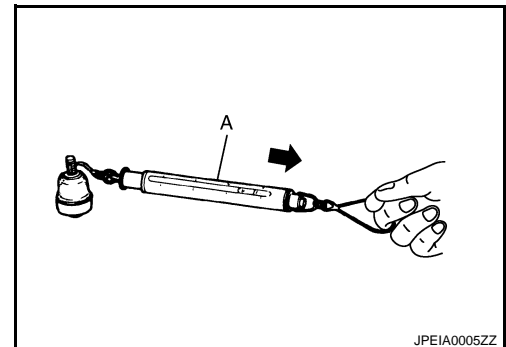

##### Axial End Play Inspection

- Move tip of ball stud in axial direction to check for looseness.

##### Standard

**Axial end play** : Refer to [FSU-45, "Ball Joint"](#).

- If it is outside the specified range, replace upper link assembly.

#### INSPECTION AFTER INSTALLATION

1. Check wheel sensor harness for proper connection. Refer to [BRC-103, "Exploded View"](#).
2. Check wheel alignment. Refer to [FSU-30, "Inspection"](#).
3. Adjust neutral position of steering angle sensor. Refer to [BRC-8, "ADJUSTMENT OF STEERING ANGLE SENSOR NEUTRAL POSITION : Special Repair Requirement"](#).



# FRONT STABILIZER

< REMOVAL AND INSTALLATION >

[AWD]

## FRONT STABILIZER

Exploded View

INFOID:000000005853927

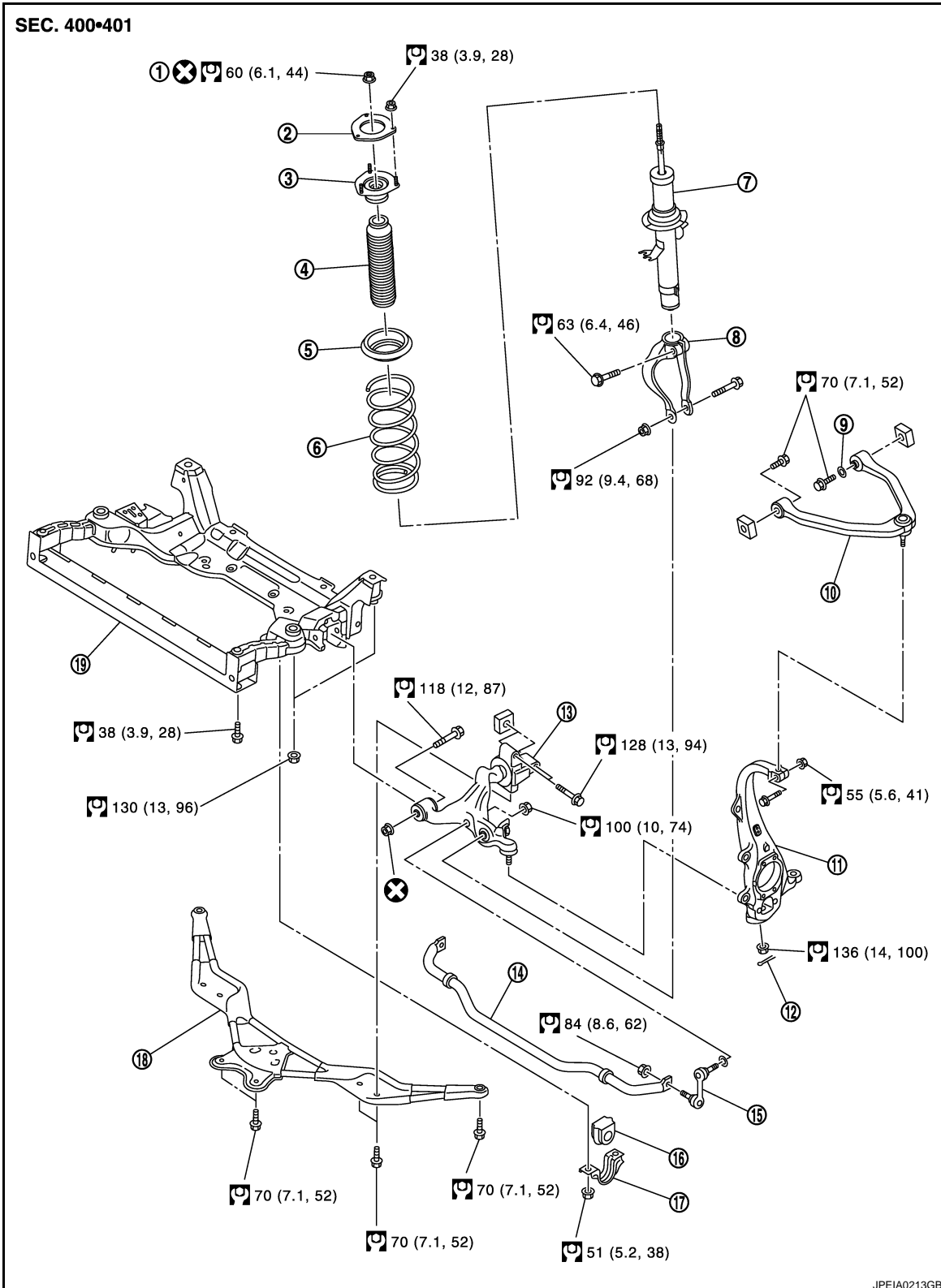

- |                        |                       |                                    |
|------------------------|-----------------------|------------------------------------|
| 1. Piston rod lock nut | 2. Mounting seal      | 3. Shock absorber mounting bracket |
| 4. Bound bumper        | 5. Rubber seat        | 6. Coil spring                     |
| 7. Shock absorber      | 8. Shock absorber arm | 9. Stopper rubber                  |

# FRONT STABILIZER

## < REMOVAL AND INSTALLATION >

[AWD]

- |                             |                      |                               |
|-----------------------------|----------------------|-------------------------------|
| 10. Upper link              | 11. Steering knuckle | 12. Cotter pin                |
| 13. Transverse link         | 14. Stabilizer bar   | 15. Stabilizer connecting rod |
| 16. Stabilizer bushing      | 17. Stabilizer clamp | 18. Front cross bar           |
| 19. Front suspension member |                      |                               |

Refer to [GI-4. "Components"](#) for symbols in the figure.

## Removal and Installation

INFOID:000000005655697

### REMOVAL

1. Remove tires with power tool.
2. Remove under cover with power tool.
3. Remove stabilizer connecting rod.

#### **CAUTION:**

**Apply a matching mark to identify the installation position.**

4. Remove the stabilizer clamp and stabilizer bushing.
5. Remove stabilizer bar.

### INSTALLATION

Note the following, and install in the reverse order of removal.

- Check the mounting mark when installing.
- Tighten the mounting nut to the specified torque while holding a hexagonal part of stabilizer connecting rod side.

### Inspection

INFOID:000000005655698

### INSPECTION AFTER REMOVAL

Check stabilizer bar, stabilizer connecting rod, stabilizer bushing and stabilizer clamp for deformation, cracks or damage. Replace it if necessary.

# FRONT SUSPENSION MEMBER

< UNIT REMOVAL AND INSTALLATION >

[AWD]

## UNIT REMOVAL AND INSTALLATION

### FRONT SUSPENSION MEMBER

Exploded View

INFOID:000000005853852

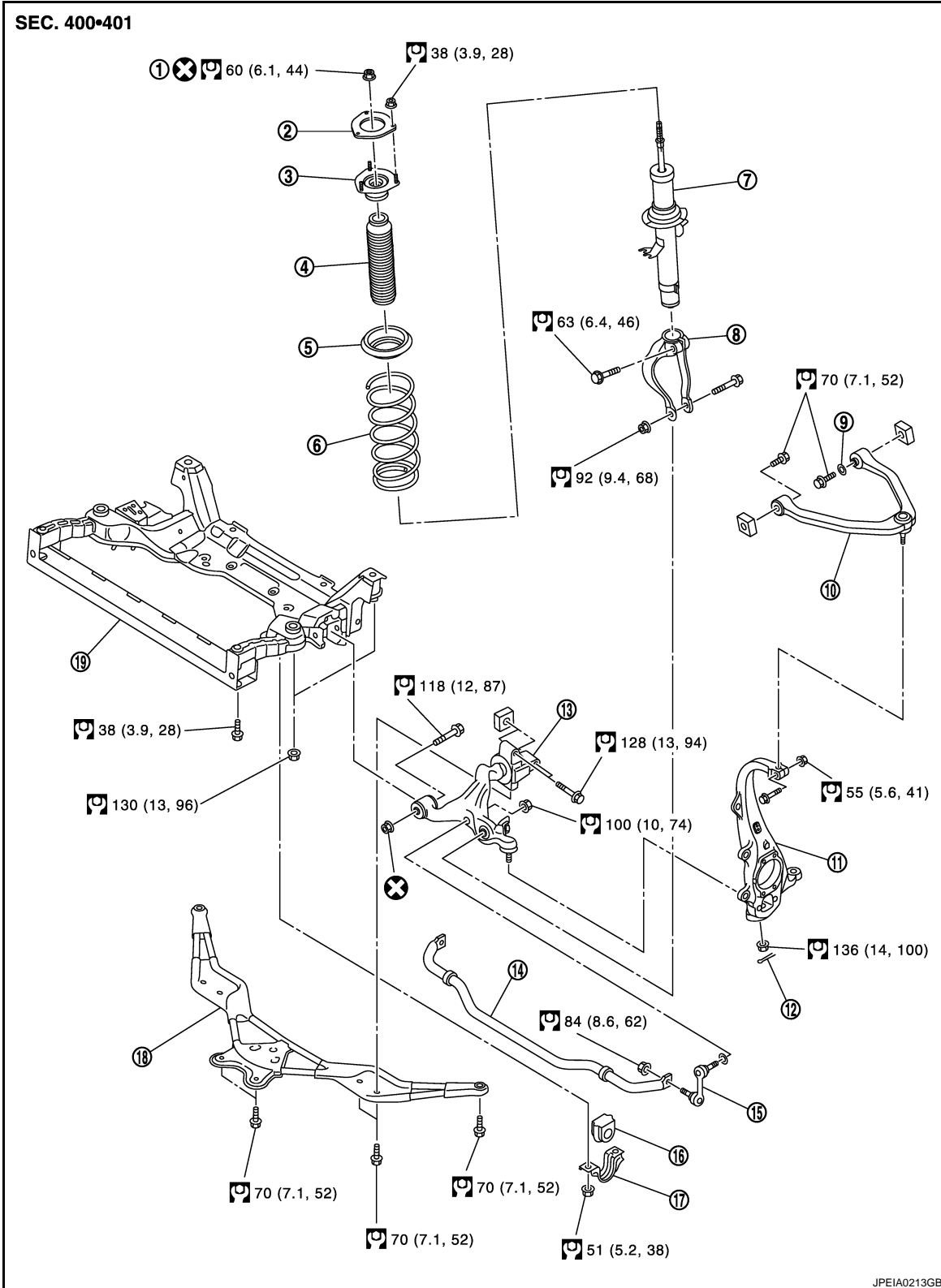

A

B

C

D

FSU

F

G

H

I

J

K

L

M

N

O

P

# FRONT SUSPENSION MEMBER

< UNIT REMOVAL AND INSTALLATION >

[AWD]

- |                             |                       |                                    |
|-----------------------------|-----------------------|------------------------------------|
| 1. Piston rod lock nut      | 2. Mounting seal      | 3. Shock absorber mounting bracket |
| 4. Bound bumper             | 5. Rubber seat        | 6. Coil spring                     |
| 7. Shock absorber           | 8. Shock absorber arm | 9. Stopper rubber                  |
| 10. Upper link              | 11. Steering knuckle  | 12. Cotter pin                     |
| 13. Transverse link         | 14. Stabilizer bar    | 15. Stabilizer connecting rod      |
| 16. Stabilizer bushing      | 17. Stabilizer clamp  | 18. Front cross bar                |
| 19. Front suspension member |                       |                                    |

Refer to [GI-4, "Components"](#) for symbols in the figure.

## Removal and Installation

INFOID:000000005853853

### REMOVAL

1. Remove tire with power tool.
2. Remove under cover with power tool.
3. Remove front cross bar.
4. Separate steering gear assembly and lower joint. Refer to [ST-24, "WITHOUT 4WAS : Exploded View"](#).
5. Remove steering outer socket from steering knuckle. Refer to [ST-37, "AWD : Exploded View"](#).
6. Remove wheel sensor from steering knuckle. Refer to [BRC-104, "FRONT SENSOR ROTOR : Exploded View"](#).
7. Remove shock absorber. Refer to [FSU-31, "Exploded View"](#).
8. Remove front stabilizer. Refer to [FSU-41, "Exploded View"](#).
9. Install engine slinger, and then hoist engine. Refer to [EM-74, "AWD : Removal and Installation"](#).
10. Remove transverse link from front suspension member with power tool. Refer to [FSU-36, "Exploded View"](#).
11. Remove steering hydraulic piping bracket and steering gear from front suspension member. Refer to [ST-61, "AWD : Exploded View"](#).
12. Set suitable jack front suspension member.
13. Remove mounting nuts between engine mounting insulator and from suspension member. Refer to [EM-73, "AWD : Exploded View"](#).
14. Remove mounting bolts and nuts of front suspension member with power tool.
15. Gradually lower jack to remove front suspension assembly from vehicle.

### INSTALLATION

Note the following, and install in the reverse order of removal.

- Perform final tightening of installation position between front suspension member and transverse links (rubber bushing) under unladen condition with tires on level ground.

### Inspection

INFOID:000000005655701

#### INSPECTION AFTER REMOVAL

Check the front suspension member for significant deformation, cracks, or damages. Replace if necessary.

#### INSPECTION AFTER INSTALLATION

1. Check wheel sensor harness for proper connection. Refer to [BRC-103, "Exploded View"](#).
2. Check wheel alignment. Refer to [FSU-30, "Inspection"](#).
3. Adjust the neutral position of the steering angle sensor. Refer to [BRC-8, "ADJUSTMENT OF STEERING ANGLE SENSOR NEUTRAL POSITION : Special Repair Requirement"](#).

## SERVICE DATA AND SPECIFICATIONS (SDS)

< SERVICE DATA AND SPECIFICATIONS (SDS)

[AWD]

# SERVICE DATA AND SPECIFICATIONS (SDS)

## SERVICE DATA AND SPECIFICATIONS (SDS)

### Wheel Alignment

INFOID:0000000005655702

Item		Standard	
Camber Degree minute (Decimal degree)	Minimum	-1° 10' (-1.16°)	
	Nominal	-0° 25' (-0.42°)	
	Maximum	0° 20' (0.33°)	
	Left and right difference	0° 33' (0.55°) or less	
Caster Degree minute (Decimal degree)	Minimum	3° 30' (3.50°)	
	Nominal	4° 15' (4.25°)	
	Maximum	5° 00' (5.00°)	
	Left and right difference	0° 39' (0.65°) or less	
Kingpin inclination Degree minute (Decimal degree)	Minimum	6° 40' (6.67°)	
	Nominal	7° 25' (7.42°)	
	Maximum	8° 10' (8.16°)	
Total toe-in	Distance	Minimum	0 mm (0 in)
		Nominal	In 1 mm (0.04 in)
		Maximum	In 2 mm (0.08 in)
	Angle (left wheel or right wheel) Degree minute (Decimal degree)	Minimum	0° 00' (0.00°)
		Nominal	In 0° 02' 30" (0.04°)
		Maximum	In 0° 05' (0.08°)

Measure value under unladen\* conditions.

\*Fuel, engine coolant and lubricant are full. Spare tire, jack, hand tools and mats are in designated positions.

### Ball Joint

INFOID:0000000005655703

Item		Standard
Swing torque	Transverse link	0.5 – 3.6 N·m (0.06 – 0.36 kg·m, 5 – 31 in-lb)
	Upper link	0 – 2.0 N·m (0 – 0.2 kg·m, 0 – 17 in-lb)
Measurement on spring balance	Transverse link	7.8 – 56.3 N (0.8 – 5.7 kg, 1.8 – 12.5 lb)
	Upper link	0 – 61.5 N (0 – 6.3 kg, 0 – 13.8 lb)
Rotating torque	Transverse link	0.5 – 3.9 N·m (0.06 – 0.39 kg·m, 5 – 34 in-lb)
Axial end play		0 mm (0 in)

### Wheelarch Height

INFOID:0000000005655704

Item	Standard
Front (Hf)	726 mm (28.58 in)

# SERVICE DATA AND SPECIFICATIONS (SDS)

< SERVICE DATA AND SPECIFICATIONS (SDS)

[AWD]

Item	Standard
Rear (Hr)	718 mm (28.27 in)

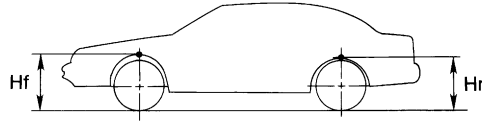

SFA818A

Measure value under unladen\* conditions.

\*: Fuel, engine coolant and lubricant are full. Spare tire, jack, hand tools and mats are in designated positions.